

User Manual

# LS Programmable Logic Controller XGT Analog Input Module

**XGF-AC8A / XGF-AV8A**



## Safety Instructions

- Read this manual carefully before installing, wiring, operating, servicing or inspecting this equipment.
- Keep this manual within easy reach for quick reference.

# Safety Instructions

## Before using the product ...

For your safety and effective operation, please read the safety instructions thoroughly before using the product.



- ▶ Safety Instructions should always be observed in order to prevent accident or risk with the safe and proper use the product.
- ▶ Instructions are separated into “Warning” and “Caution”, and the meaning of the terms is as follows;



This symbol indicates the possibility of serious injury or death if some applicable instruction is violated



This symbol indicates the possibility of slight injury or damage to products if some applicable instruction is violated

- ▶ The marks displayed on the product and in the user’s manual have the following meanings.
  -  Be careful! Danger may be expected.
  -  Be careful! Electric shock may occur.
- ▶ The user’s manual even after read should be kept available and accessible to any user of the product.

# Safety Instructions

## Safety Instructions when designing

### **Warning**

- ▶ **Please, install protection circuit on the exterior of PLC to protect the whole control system from any error in external power or PLC module.** Any abnormal output or operation may cause serious problem in safety of the whole system.
  - Install applicable protection unit on the exterior of PLC to protect the system from physical damage such as emergent stop switch, protection circuit, the upper/lowest limit switch, forward/reverse operation interlock circuit, etc.
  - If any system error (watch-dog timer error, module installation error, etc.) is detected during CPU operation in PLC, the whole output is designed to be turned off and stopped for system safety. However, in case CPU error if caused on output device itself such as relay or TR can not be detected, the output may be kept on, which may cause serious problems. Thus, you are recommended to install an addition circuit to monitor the output status.
  
- ▶ **Never connect the overload than rated to the output module nor allow the output circuit to have a short circuit,** which may cause a fire.
  
- ▶ **Never let the external power of the output circuit be designed to be On earlier than PLC power,** which may cause abnormal output or operation.
  
- ▶ **In case of data exchange between computer or other external equipment and PLC through communication or any operation of PLC (e.g. operation mode change), please install interlock in the sequence program to protect the system from any error.** If not, it may cause abnormal output or operation.

# Safety Instructions

## Safety Instructions when designing

### **Caution**

- ▶ **I/O signal or communication line shall be wired at least 100mm away from a high-voltage cable or power line.** If not, it may cause abnormal output or operation.

## Safety Instructions when designing

### **Caution**

- ▶ **Use PLC only in the environment specified in PLC manual or general standard of data sheet.** If not, electric shock, fire, abnormal operation of the product or flames may be caused.
- ▶ **Before installing the module, be sure PLC power is off.** If not, electric shock or damage on the product may be caused.
- ▶ **Be sure that each module of PLC is correctly secured.** If the product is installed loosely or incorrectly, abnormal operation, error or dropping may be caused.
- ▶ **Be sure that I/O or extension connector is correctly secured.** If not, electric shock, fire or abnormal operation may be caused.
- ▶ **If lots of vibration is expected in the installation environment, don't let PLC directly vibrated.** Electric shock, fire or abnormal operation may be caused.
- ▶ **Don't let any metallic foreign materials inside the product,** which may cause electric shock, fire or abnormal operation..

# Safety Instructions

## Safety Instructions when wiring

### **Warning**

- ▶ **Prior to wiring, be sure that power of PLC and external power is turned off.** If not, electric shock or damage on the product may be caused.
- ▶ **Before PLC system is powered on, be sure that all the covers of the terminal are securely closed.** If not, electric shock may be caused

### **Caution**

- ▶ **Let the wiring installed correctly after checking the voltage rated of each product and the arrangement of terminals.** If not, fire, electric shock or abnormal operation may be caused.
- ▶ **Secure the screws of terminals tightly with specified torque when wiring.** If the screws of terminals get loose, short circuit, fire or abnormal operation may be caused.
- \*
  - ▶ **Surely use the ground wire of Class 3 for FG terminals, which is exclusively used for PLC.** If the terminals not grounded correctly, abnormal operation may be caused.
  - ▶ **Don't let any foreign materials such as wiring waste inside the module while wiring,** which may cause fire, damage on the product or abnormal operation.

# Safety Instructions

## Safety Instructions for test-operation or repair

### **Warning**

- ▶ **Don't touch the terminal when powered.** Electric shock or abnormal operation may occur.
- ▶ **Prior to cleaning or tightening the terminal screws, let all the external power off including PLC power.** If not, electric shock or abnormal operation may occur.
- ▶ **Don't let the battery recharged, disassembled, heated, short or soldered.** Heat, explosion or ignition may cause injuries or fire.

### **Caution**

- ▶ **Don't remove PCB from the module case nor remodel the module.** Fire, electric shock or abnormal operation may occur.
- ▶ **Prior to installing or disassembling the module, let all the external power off including PLC power.** If not, electric shock or abnormal operation may occur.
- ▶ **Keep any wireless installations or cell phone at least 30cm away from PLC.** If not, abnormal operation may be caused.

## Safety Instructions for waste disposal

### **Caution**

- ▶ **Product or battery waste should be processed as industrial waste.** The waste may discharge toxic materials or explode itself.

# Revision History

Version	Date	Remark	Page
V 1.0	'06.02	First Edition	-

# © Contents ©

## Chapter 1 Introduction ..... 1-1 ~ 1-3

1.1 Characteristics .....	1-1
1.2 Terminology.....	1-2
1.2.1 Analog quantity - A .....	1-2
1.2.2 Digital quantity - D .....	1-2
1.2.3 Characteristics of analog/digital conversion .....	1-3

## Chapter 2 Specifications ..... 2-1 ~ 2-18

2.1 General Specifications .....	2-1
2.2 Performance Specifications .....	2-2
2.3 Respective Designations and Functions .....	2-4
2.3.1 XGF-AV8A/AC8A .....	2-4
2.4 Characteristic of I/O conversion .....	2-5
2.4.1 I/O characteristics of XGF-AV8A .....	2-6
1) If the range is DC 1 ~ 5 V .....	2-6
2) If the range is DC 0 ~ 5 V .....	2-7
3) If the range is DC 0 ~ 10 V .....	2-8
4) If the range is DC-10 ~ 10 V .....	2-9
2.4.2 I/O characteristics of XGF-AC8A .....	2-10
1) If the range is DC 4 ~ 20 mA .....	2-10
2) If the range is DC 0 ~ 20 mA .....	2-11
2.4.3 Accuracy .....	2-13
2.5 Functions of Analog Input Module .....	2-14
2.5.1 Sampling processing .....	2-14
2.5.2 Filter processing.....	2-15
1) In the case of XGF-AV8A .....	2-15
2) In the case of XGF-AC8A .....	2-15
2.5.3 Average processing.....	2-16
1) What is the average processing used for .....	2-16
2) Average processing type .....	2-16
(1) Time average processing .....	2-16
(2) Count average processing .....	2-17

2.5.4 Input disconnection detection function .....	2-17
--	------

<b>Chapter 3 Installation and Wiring .....</b>	<b>3-1 ~ 3-4</b>
--	------------------

3.1 Installation .....	3-1
3.1.1 Installation environment .....	3-1
1) Environmental conditions .....	3-1
2) Installation work .....	3-1
3.1.2 Precautions for handling .....	3-1
3.2 Wiring .....	3-2
3.2.1 Precautions for wiring .....	3-2
3.2.2 Wiring example .....	3-2
1) XGF-AV8A .....	3-2
2) XGF-AC8A .....	3-2
3) Wiring example of 2-Wire Sensor Transmitter (current input) .....	3-3
4) Wiring example of 4-Wire Sensor Transmitter (voltage/current input) .....	3-3
5) Relationship between voltage input accuracy and wiring length .....	3-4

<b>Chapter 4 Operation Procedures and Monitoring .....</b>	<b>4-1 ~ 4-17</b>
--	-------------------

4.1 Operation Procedures .....	4-1
4.2 Operation Parameters Setting .....	4-2
4.2.1 Settings .....	4-2
4.2.2 I/O parameters .....	4-2
4.3 Special Module Monitoring Functions .....	4-8
4.4 Precautions .....	4-9
4.5 Special Module Monitoring .....	4-10
4.5.1 Start of [Special Module Monitoring] .....	4-10
4.5.2 How to use [Special Module Monitoring] .....	4-10
4.6 Register U Devices .....	4-14
4.6.1 Register U devices.....	4-14
4.6.2 Save variables.....	4-15
4.6.3 View variables .....	4-16

## **Chapter 5 Configuration and Function of Internal Memory ..... 5-1 ~ 5-10**

5.1 Internal Memory Configuration .....	5-1
5.1.1 I/O area of A/D converted data .....	5-1
5.1.2 Operation parameters setting area .....	5-2
5.2 A/D Converted Data I/O Area .....	5-3
5.2.1 Module READY/ERROR flag .....	5-3
5.2.2 Run channel flag .....	5-3
5.2.3 Digital output value .....	5-3
5.2.4 Flag to detect disconnection .....	5-4
5.2.5 Flag to request error clear .....	5-4
5.3 Operation Parameters Setting Area .....	5-5
5.3.1 How to specify the channel to use .....	5-5
5.3.2 How to specify the range of input voltage/current .....	5-5
5.3.3 How to specify the range of output data .....	5-6
5.3.4 How to specify filter process .....	5-7
5.3.5 How to specify filter constant .....	5-7
5.3.6 How to specify average process .....	5-8
5.3.7 How to specify average processing method .....	5-8
5.3.8 How to specify average value .....	5-9
5.3.9 Error code .....	5-10

## **Chapter 6 Programming ..... 6-1 ~ 6-12**

6.1 Read/Write of Operation Parameters Setting Area .....	6-1
6.1.1 Read of operation parameters setting area (GET, GETP command) .....	6-1
6.1.2 Write of operation parameters setting area (PUT, PUTP command) .....	6-2
6.2 Basic Program .....	6-3
6.2.1 XGF-AV8A .....	6-3
1) Program example using [I/O parameters] setting .....	6-3
2) Program example using PUT/GET command .....	6-4
6.2.2 XGF-AC8A .....	6-5
1) Program example using [I/O parameters] setting .....	6-5
2) Program example using PUT/GET command .....	6-6
6.3 Application Program .....	6-7
6.3.1 Program to sort A/D converted value in size .....	6-7

1) System configuration .....	6-7
2) Details of initial setting .....	6-7
3) Program description .....	6-7
4) Program .....	6-8
(1) Program example using [I/O parameters] setting .....	6-8
(2) Program example using PUT/GET command .....	6-9
6.3.2 Program to output error codes of analog input module to BCD display .....	6-10
1) System Configuration .....	6-10
2) Details of initial setting .....	6-10
3) Program description .....	6-10
4) Program .....	6-11
(1) Program example through [I/O parameters] setting .....	6-11
(2) Program example with PUT/GET command used .....	6-12

<b>Chapter 7 Troubleshooting .....</b>	<b>7-1 ~ 7-5</b>
--	------------------

7.1 Error Codes .....	7-1
7.2 Troubleshooting .....	7-2
7.2.1 RUN LED blinks .....	7-2
7.2.2 RUN LED is Off .....	7-3
7.2.3 CPU module can not read A/D converted value .....	7-3
7.2.4 Relationship discordant between analog input value & digital output value .....	7-4
7.2.5 H/W error of A/D conversion module .....	7-4
7.2.6 Status check of A/D conversion module through XG5000 system monitor .....	7-4
1) Execution sequence .....	7-4
2) Module information .....	7-4

<b>Appendix .....</b>	<b>Appendix -1 ~ Appendix - 3</b>
-----------------------	-----------------------------------

Appendix 1 Terminology .....	Appendix -1
Appendix 2 External Dimensions .....	Appendix -3
1) External dimensions of XGF-AV8A/AC8A .....	Appendix -3

<b>Index .....</b>	<b>Index-1</b>
--------------------	----------------

## Chapter 1 Introduction

This user's manual is to describe XGF-AV8A type of analog voltage to digital conversion module (hereinafter referred to as XGF-AV8A) and XGF-AC8A type of analog current to digital conversion module (hereinafter referred to as XGF-AC8A) used as associated with XGT PLC series of CPU module about their specifications, treatment and programming, which will be hereinafter referred to as A/D conversion module, a general term of XGF-AV8A and XGF-AC8A.

A/D conversion module is used to convert analog signal (voltage or current input) from PLC's external device to signed 16-bit binary data of digital value.

### 1.1 Characteristics

- 1) Selection of a module based on purpose
  - XGF-AV8A: 8 channels, voltage input
  - XGF-AC8A: 8 channels, current input
- 2) High speed conversion  
High speed conversion can be processed through 250  $\mu$ s/channel.
- 3) High accuracy  
High conversion accuracy of  $\pm 0.2$  % (ambient temperature of  $25 \pm 5$  °C) is available.
- 4) High resolution of 1/16000  
High resolution of 1/16000 can be selected to obtain digital value of high resolution.
- 5) Operation parameters setting / monitoring through GUI (Graphical User Interface)  
Operation parameters setting which was by using traditional commands is available now by means of [I/O Parameters Setting] for which user interface is reinforced to increase user's convenience. With [I/O Parameters Setting] used, the sequence program can be reduced. In addition, through [Special Module Monitoring] function, A/D conversion value can be easily monitored.
- 6) Various formats of digital output data provided  
4 formats of digital output data are available as specified below;
  - Unsigned Value: 0 ~ 16000
  - Signed Value: -8000 ~ 8000
  - Precise Value: Refer to Chapter 2.2 Display based on analog input range.
  - Percentile Value: 0 ~ 10000
- 7) Input disconnection detection function  
This function is used to detect the disconnection of input circuit when 1 ~ 5 V (4 ~ 20 mA) of analog input signal range is used.

**1.2. Terminology**

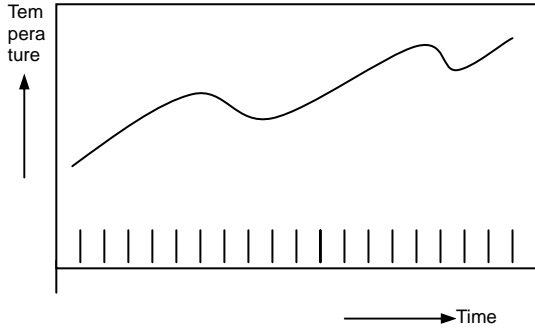

[Fig. 1.1] Analog Quantity

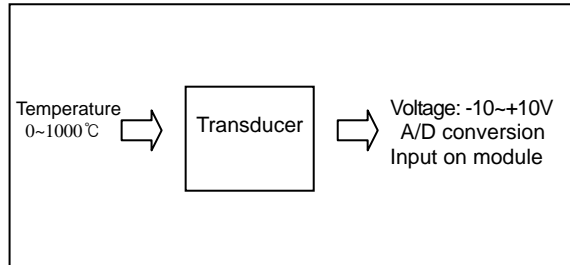

[Fig. 1.2] Example of Transducer

**1.2.1 Analog quantity - A**

What is displayed in numerical value with continuous physical quantity is called Analog Quantity. Since the size of analog changes continuously, any middle value can be taken from it in which general physical quantities such as voltage, current, temperature, speed, pressure and flow are included. For example, temperature can change continuously together with time as shown in Fig. 1.1. Since the changing temperature can not be input directly on A/D conversion module, it shall be input on A/D conversion module through the transducer converting identical analog quantity of input signal to electric signal.

**1.2.2 Digital quantity - D**

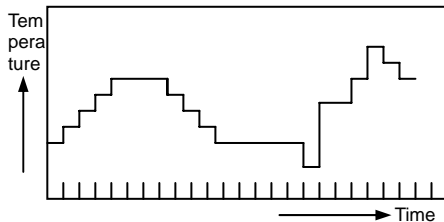

[Fig. 1.3 Digital Quantity]

What is displayed in data or numerical value such as 0, 1, 2 and 3 with data or physical quantity is called Digital Quantity. Digital in (Fig. 1.3) stands for electronic technology to create, save and process the data through 0 and 1 only. Accordingly, the data sent or saved with digital technology will be displayed in a string of 0 and 1 continuously used. For example, On and Off signal can be displayed in a digital quantity of 0 and 1. BCD and binary value is also the digital quantity.

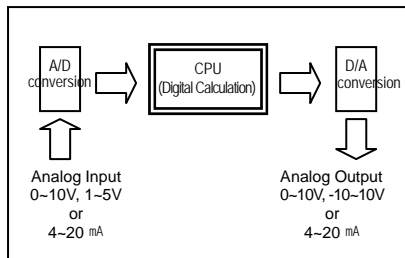

[Fig. 1.4] Process in PLC

Analog quantity can not be directly input on PLC CPU for calculation. Thus, convert analog quantity to digital quantity as in Fig. 1.4 so to input on PLC CPU, which will be executed by A/D conversion module.

In addition, in order to output the analog quantity outward, convert PLC CPU's digital quantity to analog quantity, which will be executed by D/A conversion module

### 1.2.3. Characteristics of analog/digital conversion

#### 1) Voltage Input

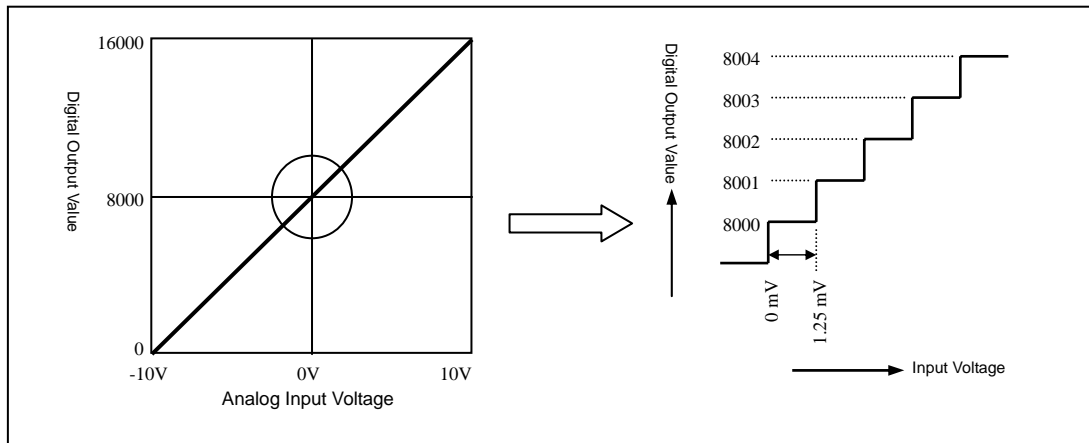

[Fig. 1.5] Characteristics of A/D conversion (Voltage Input)

A/D conversion module is used to convert analog electric signal input from the external device to digital quantity. Analog input signal converted to digital quantity can be calculated in PLC CPU. If analog input range of  $-10 \sim 10$  V is used in voltage type of A/D conversion module,  $-10$  V of analog input quantity will be output with digital value of 0, and  $10$  V of analog input quantity will be output with digital value of 16000, where consequently, analog input of  $1.25$  mV is equivalent to digital value of 1. (Fig. 1.5)

#### 2) Current Input

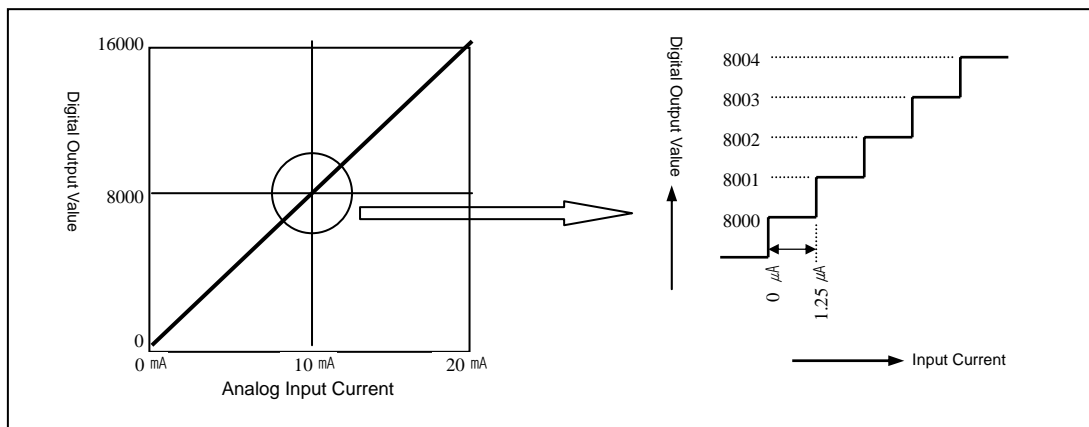

[Fig. 1.6] Characteristics of A/D conversion (Current Input)

If analog input range of  $0 \sim 20$  mA is used in current type of A/D conversion module,  $0$  mA of analog input quantity will be output with digital value of 0, and  $20$  mA of analog input quantity will be output with digital value of 16000, where consequently, analog input of  $1.25$   $\mu$ A is equivalent to digital value of 1. (Fig. 1.6)

## Chapter 2 Specifications

### 2.1 General Specifications

General specifications of XGT series are as specified in Table 2.1.

[Table 2.1] General Specifications

No.	Item	Specifications	Related standards				
1	Operating temp.	0°C ~ +55°C					
2	Storage temp.	-25°C ~ +70°C					
3	Operating humidity	5 ~ 95%RH (Non-condensing)					
4	Storage humidity	5 ~ 95%RH (Non-condensing)					
5	Vibration	For discontinuous vibration				Each 10 times in X,Y,Z directions	IEC61131-2
		Frequency	Acceleration	Amplitude	Number		
		10≤f< 57 Hz	-	0.075mm	-		
		57≤f≤150 Hz	9.8m/s <sup>2</sup> (1G)	-	-		
		For continuous vibration					
		Frequency	Acceleration	Amplitude	-		
		10≤f< 57 Hz	-	0.035mm	-		
57≤f≤150 Hz	4.9m/s <sup>2</sup> (0.5G)	-	-				
6	Shocks	* Max. impact acceleration:147 m/s <sup>2</sup> (15G) * Authorized time :11 ms * Pulse wave : Sign half-wave pulse (Each 3 times in X,Y,Z directions)				IEC61131-2	
7	Noise	Square wave impulse noise		±1,500V		LSIS standard	
		Electrostatic discharging		Voltage : 4kV(contact discharging)		IEC61131-2 IEC61000-4-2	
		Radiated electromagnetic field noise		27 ~ 500MHz, 10 V/m		IEC61131-2, IEC61000-4-3	
		Fast Transient /burst noise	Class	Power module	Digital/ Analog I/O communication interface		IEC61131-2 IEC61000-4-4
Voltage	2kV		1kV				
8	Ambient conditions	No corrosive gas or dust					
9	Operating height	2000m or less					
10	Pollution degree	2 or less					

#### Notes

- 1) IEC (International Electrotechnical Commission):  
An international nongovernmental organization which promotes internationally cooperated standardization in electric/electronic fields publishes international standards and manages applicable estimation system related with.
- 2) Pollution level: An index indicating pollution level of the operating environment which decides insulation performance of the devices. For instance, Pollution level 2 indicates the state generally that only non-conductive pollution occurs. However, this state contains temporary conduction due to dew produced.

**2.2 Performance Specifications**

Performance specifications of A/D conversion modules are as specified in Table 2.2.

[Table 2.2] Performance Specifications

Item	Specifications																																
	XGF-AV8A (Voltage Input Type)		XGF-AC8A (Current Input Type)																														
Analog input	DC 1 ~ 5 V DC 0 ~ 5 V DC 0 ~ 10 V DC -10 ~ 10 V (Input Resistance: 1 MΩ min.)		DC 4 ~ 20 ma DC 0 ~ 20 ma (Input Resistance 250 Ω)																														
Analog input range setting	▶ Analog input range can be selected through XG5000 user's (or sequence) program or [I/O parameter]. ▶ Respective input ranges can be set based on channels.																																
Digital output	(1) Voltage Type																																
	<table border="1"> <tr> <td>Analog input</td> <td>1 ~ 5 V</td> <td>0 ~ 5 V</td> <td>0 ~ 10 V</td> <td>-10 ~ 10 V</td> </tr> <tr> <td>Digital output</td> <td colspan="4">0 ~ 16000</td> </tr> <tr> <td>Unsigned Value</td> <td colspan="4">0 ~ 16000</td> </tr> <tr> <td>Signed Value</td> <td colspan="4">-8000 ~ 8000</td> </tr> <tr> <td>Precise Value</td> <td>1000 ~ 5000</td> <td>0 ~ 5000</td> <td>0 ~ 10000</td> <td>-10000 ~ 10000</td> </tr> <tr> <td>Percentile Value</td> <td colspan="4">0 ~ 10000</td> </tr> </table>	Analog input	1 ~ 5 V	0 ~ 5 V	0 ~ 10 V	-10 ~ 10 V	Digital output	0 ~ 16000				Unsigned Value	0 ~ 16000				Signed Value	-8000 ~ 8000				Precise Value	1000 ~ 5000	0 ~ 5000	0 ~ 10000	-10000 ~ 10000	Percentile Value	0 ~ 10000					
Analog input	1 ~ 5 V	0 ~ 5 V	0 ~ 10 V	-10 ~ 10 V																													
Digital output	0 ~ 16000																																
Unsigned Value	0 ~ 16000																																
Signed Value	-8000 ~ 8000																																
Precise Value	1000 ~ 5000	0 ~ 5000	0 ~ 10000	-10000 ~ 10000																													
Percentile Value	0 ~ 10000																																
Digital output	(2) Current Type																																
	<table border="1"> <tr> <td>Analog input</td> <td>4 ~ 20 mA</td> <td colspan="2">0 ~ 20 mA</td> </tr> <tr> <td>Digital output</td> <td colspan="3">0 ~ 16000</td> </tr> <tr> <td>Unsigned Value</td> <td colspan="3">0 ~ 16000</td> </tr> <tr> <td>Signed Value</td> <td colspan="3">-8000 ~ 8000</td> </tr> <tr> <td>Precise Value</td> <td>4000 ~ 20000</td> <td colspan="2">0 ~ 20000</td> </tr> <tr> <td>Percentile Value</td> <td colspan="3">0 ~ 10000</td> </tr> </table>	Analog input	4 ~ 20 mA	0 ~ 20 mA		Digital output	0 ~ 16000			Unsigned Value	0 ~ 16000			Signed Value	-8000 ~ 8000			Precise Value	4000 ~ 20000	0 ~ 20000		Percentile Value	0 ~ 10000										
Analog input	4 ~ 20 mA	0 ~ 20 mA																															
Digital output	0 ~ 16000																																
Unsigned Value	0 ~ 16000																																
Signed Value	-8000 ~ 8000																																
Precise Value	4000 ~ 20000	0 ~ 20000																															
Percentile Value	0 ~ 10000																																
	▶ 16-bit binary value (data: 14 bits) ▶ Format of digital output data can be set through user program or S/W package respectively based on channels.																																
Max. resolution	<table border="1"> <thead> <tr> <th>Analog input range</th> <th>Resolution (1/16000)</th> <th>Analog input range</th> <th>Resolution (1/16000)</th> </tr> </thead> <tbody> <tr> <td>1 ~ 5 V</td> <td>0.250 mV</td> <td rowspan="2">4 ~ 20 mA</td> <td rowspan="2">1.0 μA</td> </tr> <tr> <td>0 ~ 5 V</td> <td>0.3125 mV</td> </tr> <tr> <td>0 ~ 10 V</td> <td>0.625 mV</td> <td rowspan="2">0 ~ 20 mA</td> <td rowspan="2">1.25 μA</td> </tr> <tr> <td>-10 ~ 10 V</td> <td>1.250 mV</td> </tr> </tbody> </table>				Analog input range	Resolution (1/16000)	Analog input range	Resolution (1/16000)	1 ~ 5 V	0.250 mV	4 ~ 20 mA	1.0 μA	0 ~ 5 V	0.3125 mV	0 ~ 10 V	0.625 mV	0 ~ 20 mA	1.25 μA	-10 ~ 10 V	1.250 mV													
Analog input range	Resolution (1/16000)	Analog input range	Resolution (1/16000)																														
1 ~ 5 V	0.250 mV	4 ~ 20 mA	1.0 μA																														
0 ~ 5 V	0.3125 mV																																
0 ~ 10 V	0.625 mV	0 ~ 20 mA	1.25 μA																														
-10 ~ 10 V	1.250 mV																																
Accuracy	±0.2% or less (when ambient temperature is 25 °C ±5 °C) ±0.3% or less (when ambient temperature is 0 °C ~ 55 °C)																																
Max. conversion speed	250 μs/channel																																
Absolute max. input	±15 V		±30 mA																														
Analog input points	8 channels/1 module																																
Insulation method	Photo-coupler insulation between input terminal and PLC power (no insulation between channels)																																
Terminal connected	18-point terminal																																
I/O points occupied	Fixed type: 64 points, Changeable type: 16 points																																
Internal-consumed current	DC 5 V: 420 mA																																
Weight	140g																																

### Notes

- 1) When A/D conversion module is released from the factory, Offset/Gain value is as adjusted for respective analog input ranges, which is unavailable for user to change.
- 2) Offset Value: Analog input value where digital output value is 0 when digital output format is set to Unsigned Value.
- 3) Gain Value: Analog input value where digital output value is 16000 when digital output format is set to Unsigned Value.

**2.3 Respective Designations and Functions**

Respective designations of the parts are as described below.

**2.3.1 XGF-AV8A/XGF-AC8A**

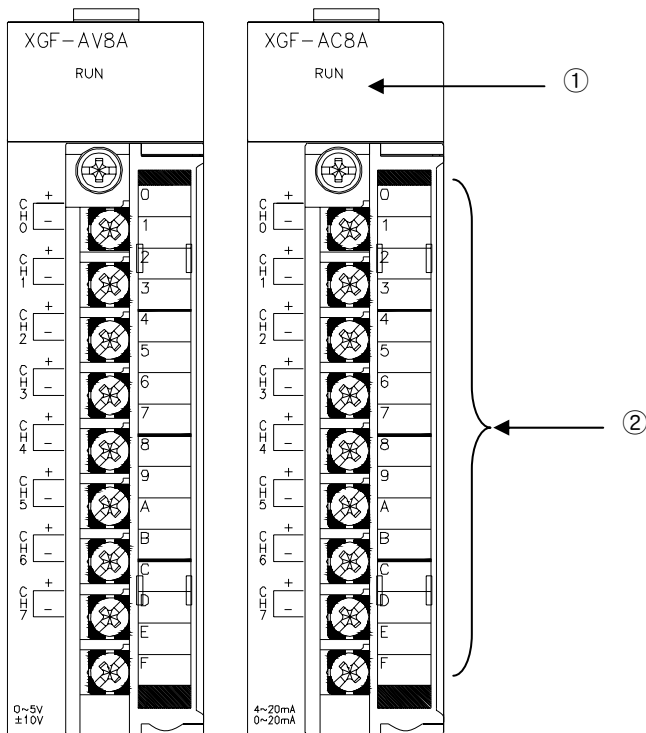

No.	Description
①	<p>RUN LED</p> <ul style="list-style-type: none"> <li>▶ Displays the operation status of XGF-AV8A/XGF-AC8A</li> <li>On: Operation normal</li> <li>Flickering: Error occurs (Refer to 7.1 for more details)</li> <li>Off: DC 5V disconnected, XGF-AV8A/XGF-AC8A module error</li> </ul>
②	<p>Terminal</p> <ul style="list-style-type: none"> <li>▶ Analog input terminal, whose respective channels can be connected with external devices.</li> </ul>

## 2.4 Characteristics of I/O Conversion

Characteristics of I/O conversion are the inclination connected in a straight line between Offset and Gain values when converting analog signal (voltage or current input) from PLC's external device to digital value. I/O conversion characteristics of A/D conversion modules are as described below.

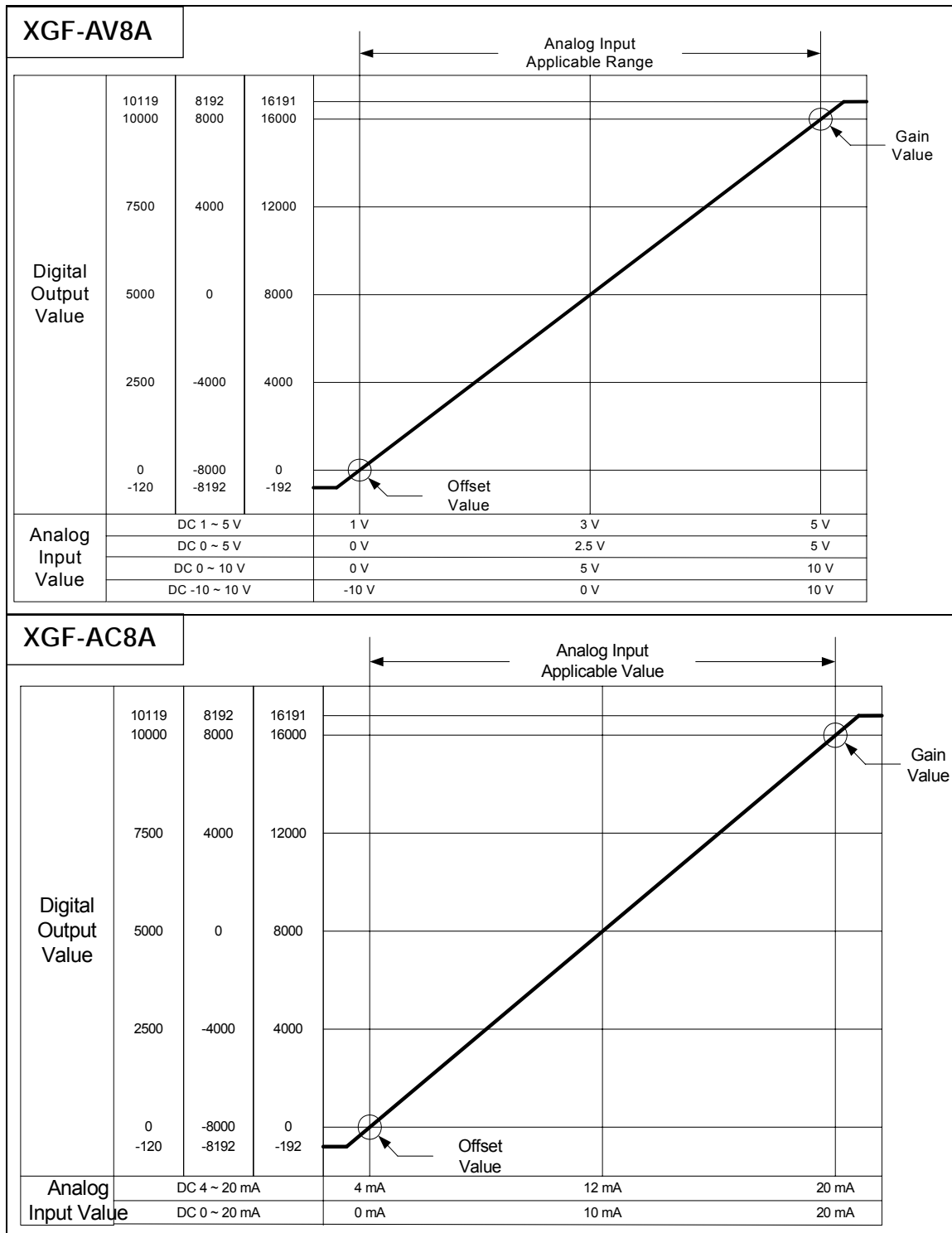

### 2.4.1 I/O characteristics of XGF-AV8A

XGF-AV8A is a module exclusively used for 8-channel analog voltage, where Offset/Gain can not be adjusted by user. Voltage input range can be set through user program or special module package for respective channels. Output formats of digital data are as specified below;

- A. Unsigned Value
- B. Signed Value
- C. Precise Value
- D. Percentile Value

1) If the range is DC 1 ~ 5 V

- ▶ On the XG5000 menu [I/O Parameters Setting], set [Input range] to "1 ~ 5 V".

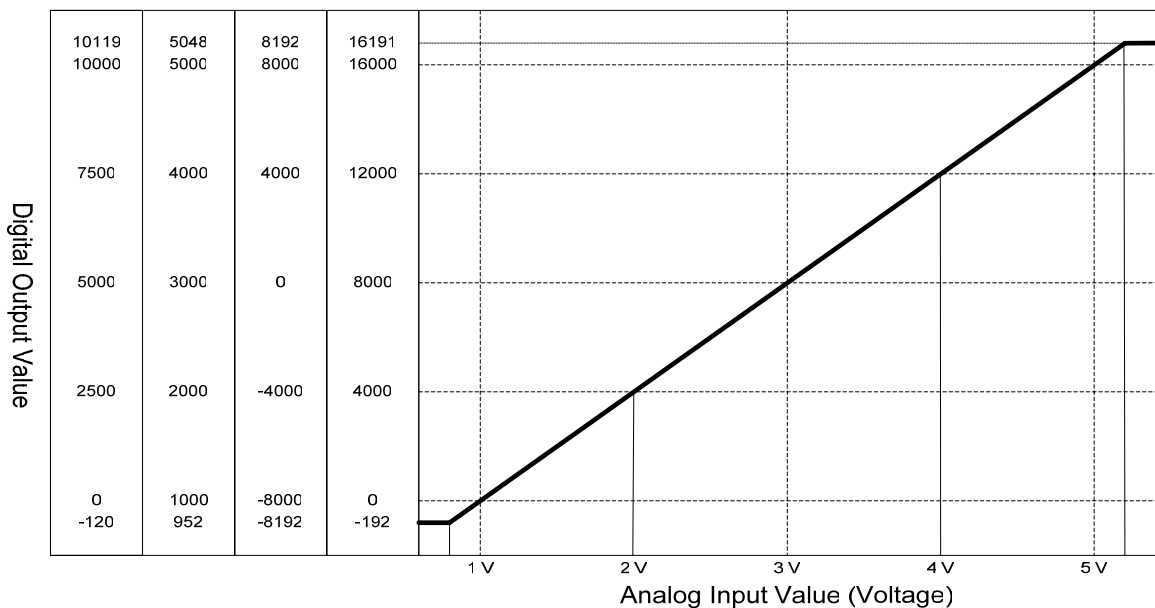
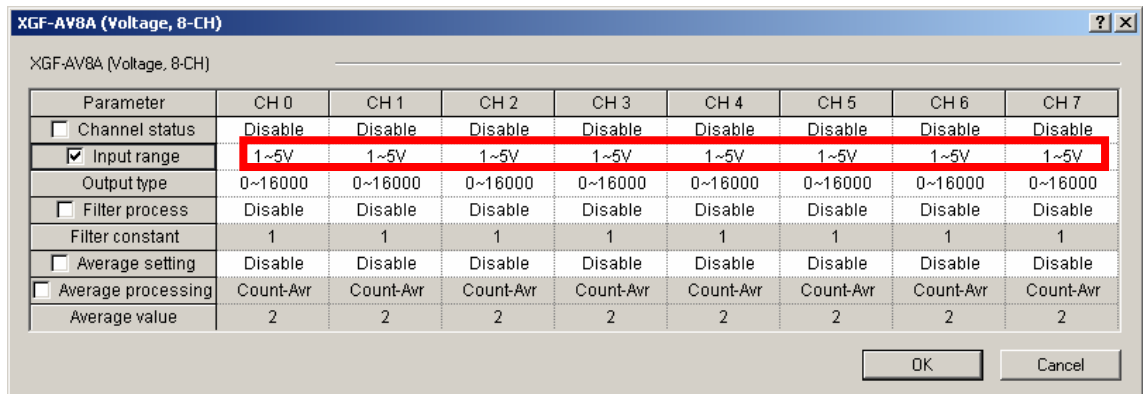

- ▶ Digital output value for voltage input characteristics is as specified below.  
(Resolution (based on 1/16000): 0.25 mV)

Digital Output range	Analog input voltage (V)						
	0.952	1	2	3	4	5	5.047
Unsigned value (-192 ~ 16191)	-192	0	4000	8000	12000	16000	16191
Signed value (-8192 ~ 8191)	-8192	-8000	-4000	0	4000	8000	8191

Precise value (952 ~ 5048)	952	1000	2000	3000	4000	5000	5048
Percentile value (-120 ~ 10119)	-120	0	2500	5000	7500	10000	10119

- 2) If the range is DC 0 ~ 5 V  
 ► On the XG5000 menu [I/O Parameters Setting], set [Input range] to "0 ~ 5 V".

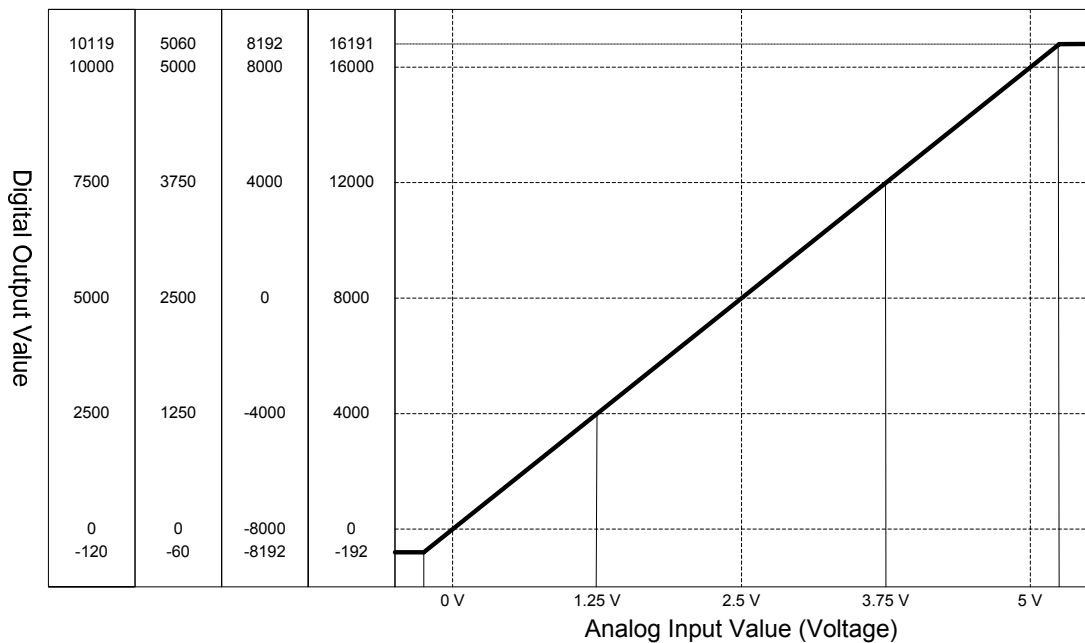
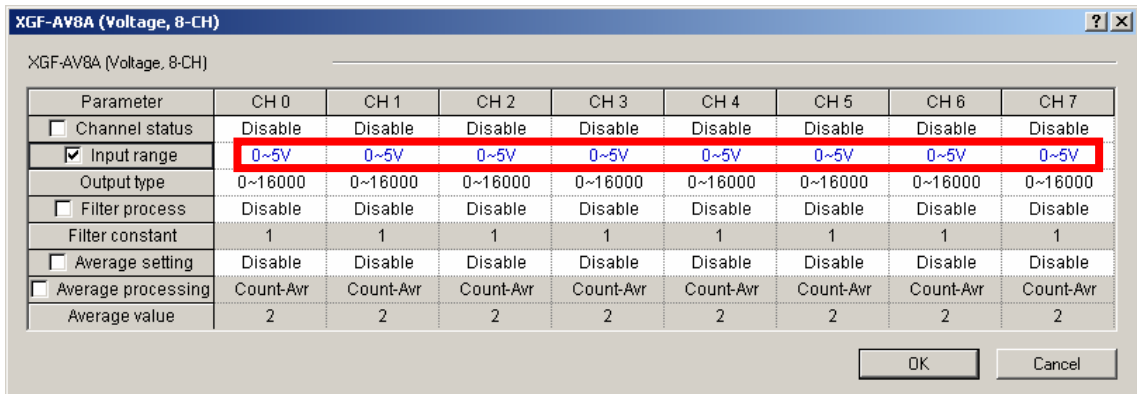

- Digital output value for voltage input characteristics is as specified below.  
 (Resolution (based on 1/16000): 0.3125 mV)

Digital Output range	Analog input voltage (V)						
	-0.06	0	1.25	2.5	3.75	5	5.05
Unsigned value (-192 ~ 16191)	-192	0	4000	8000	12000	16000	16191
Signed value (-8192 ~ 8191)	-8192	-8000	-4000	0	4000	8000	8191
Precise value (-60 ~ 5060)	-60	0	1250	2500	3750	5000	5060
Percentile value (-120 ~ 10119)	-120	0	2500	5000	7500	10000	10119

## Chapter 2 Specifications

- 3) If the range is DC 0 ~ 10 V  
 ▶ On the XG5000 menu [I/O Parameters Setting], set [Input range] to "0 ~ 10 V".

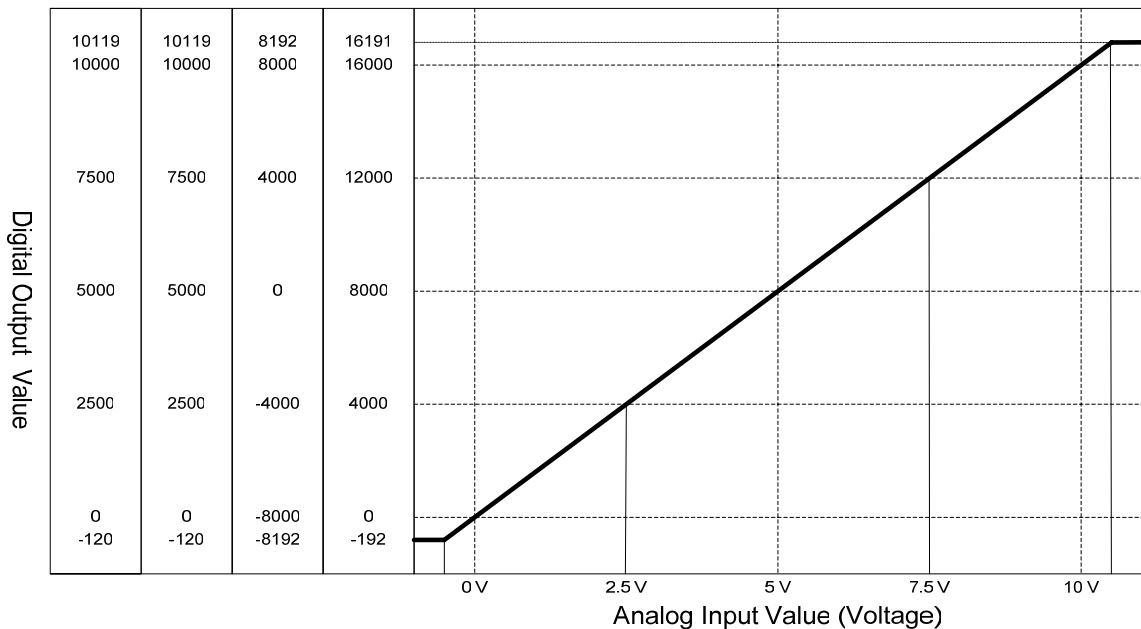
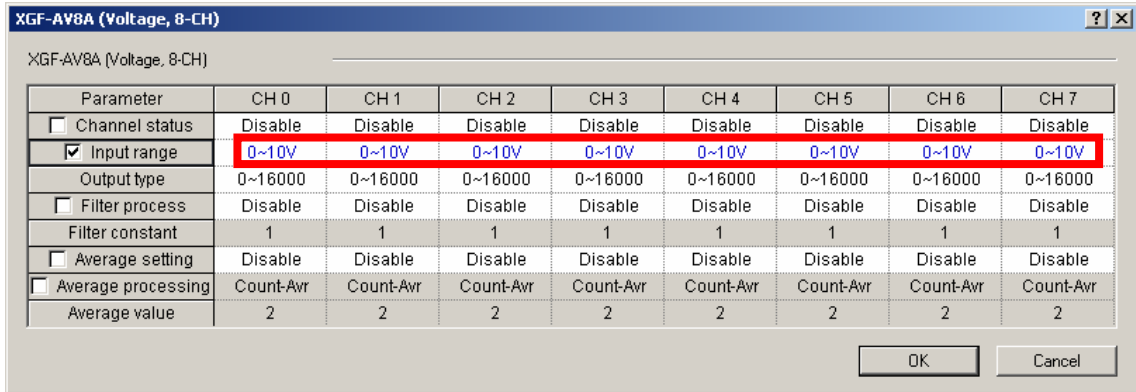

- ▶ Digital output value for voltage input characteristics is as specified below.  
 (Resolution (based on 1/16000): 0.625 mV)

Digital Output range	Analog input voltage (V)						
	-0.12	0	2.5	5	7.5	10	10.11
Unsigned value (-192 ~ 16191)	-192	0	4000	8000	12000	16000	16191
Signed value (-8192 ~ 8191)	-8192	-8000	-4000	0	4000	8000	8191
Precise value (-60 ~ 5059)	-120	0	2500	5000	7500	10000	10119
Percentile value (-120 ~ 10119)	-120	0	2500	5000	7500	10000	10119

- 4) If the range is DC-10 ~ 10 V  
 ▶ On the XG5000 menu [I/O Parameters Setting], set [Input range] to “-10 ~ 10 V”.

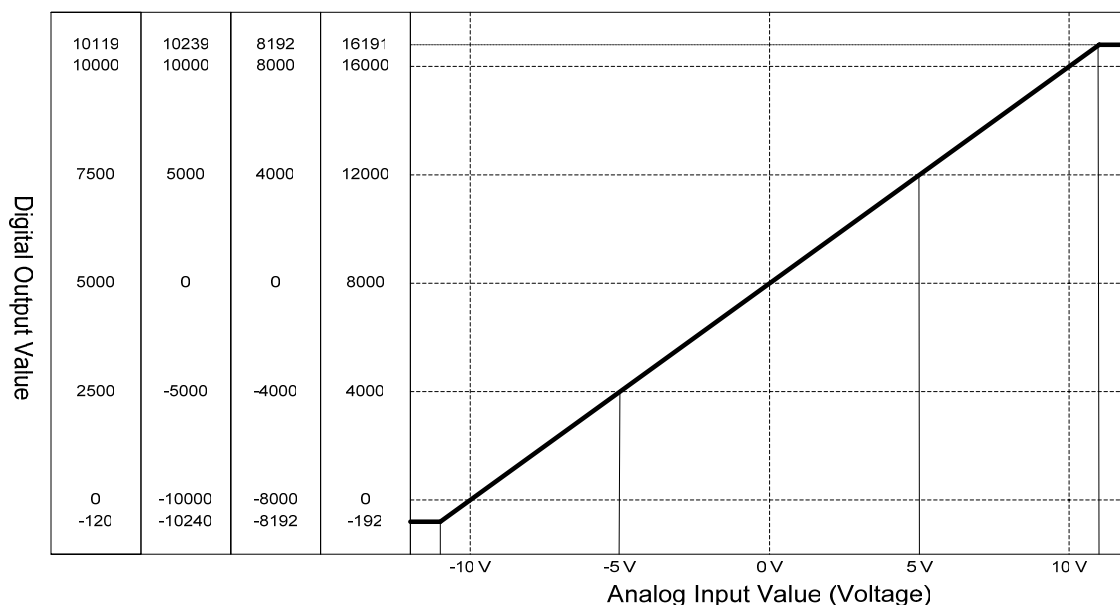
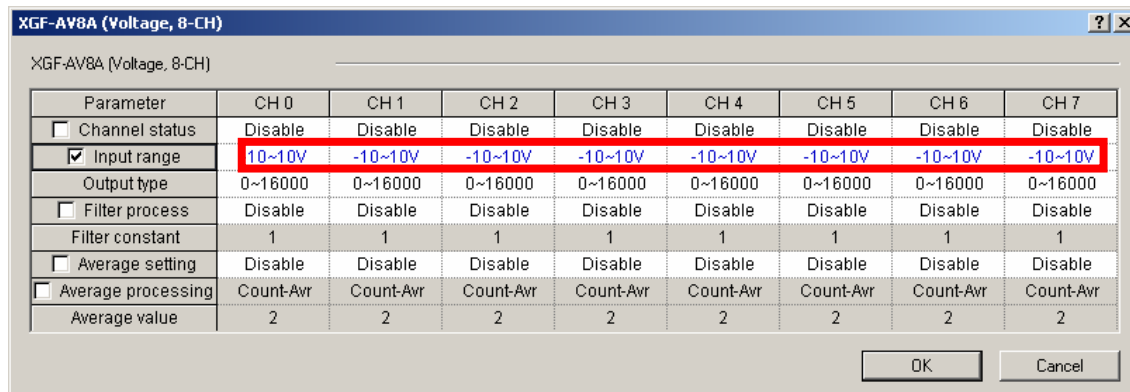

- ▶ Digital output value for voltage input characteristics is as specified below.  
 (Resolution (based on 1/16000): 1.25 mV)

Digital Output range	Analog input voltage (V)						
	-0.24	-10	-5	0	5	10	10.23
Unsigned value (-192 ~ 16191)	-192	0	4000	8000	12000	16000	16191
Signed value (-8192 ~ 8191)	-8192	-8000	-4000	0	4000	8000	8191
Precise value (-10240 ~ 10238)	-10240	0	2500	5000	7500	10000	10239
Percentile value (-120 ~ 10119)	-120	0	2500	5000	7500	10000	10119

2.4.2 I/O characteristics of XGF-AC8A

Current input range can be set through user program or special module package for respective channels. Output formats of digital data are as specified below;

- A. Unsigned Value
- B. Signed Value
- C. Precise Value
- D. Percentile Value

1) If the range is DC 4 ~ 20 mA

▶ On the XG5000 menu [I/O Parameters Setting], set [Input range] to “4 ~ 20 mA”.

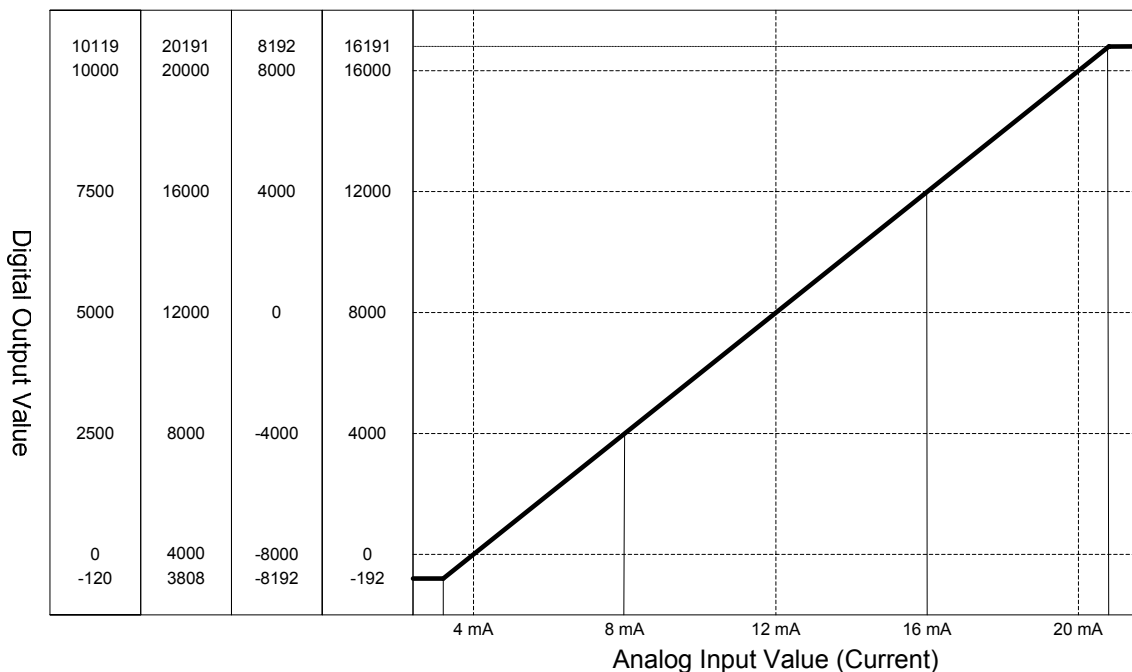
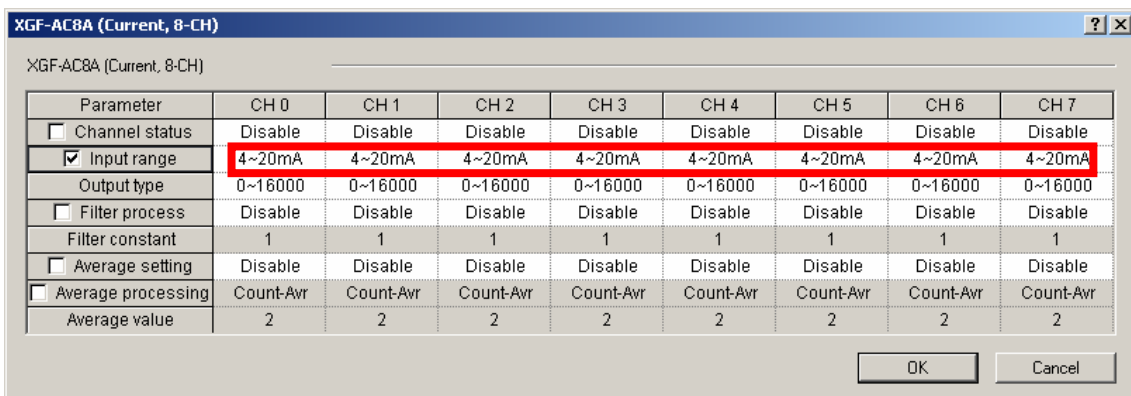

- ▶ Digital output value for current input characteristics is as specified below.  
(Resolution (based on 1/16000): 1  $\mu$ A)

Digital Output range	Analog input current (mA)						
	3.808	4	8	12	16	20	20.191
Unsigned value (-192 ~ 16191)	-192	0	4000	8000	12000	16000	16191
Signed value (-8192 ~ 8191)	-8192	-8000	-4000	0	4000	8000	8191
Precise value (3808 ~ 20191)	3808	4000	8000	12000	16000	20000	20191
Percentile value (-120 ~ 10119)	-120	0	2500	5000	7500	10000	10119

- 2) If the range is DC 0 ~ 20 mA
  - ▶ On the XG5000 menu [I/O Parameters Setting], set [Input range] to "0 ~ 20 mA".

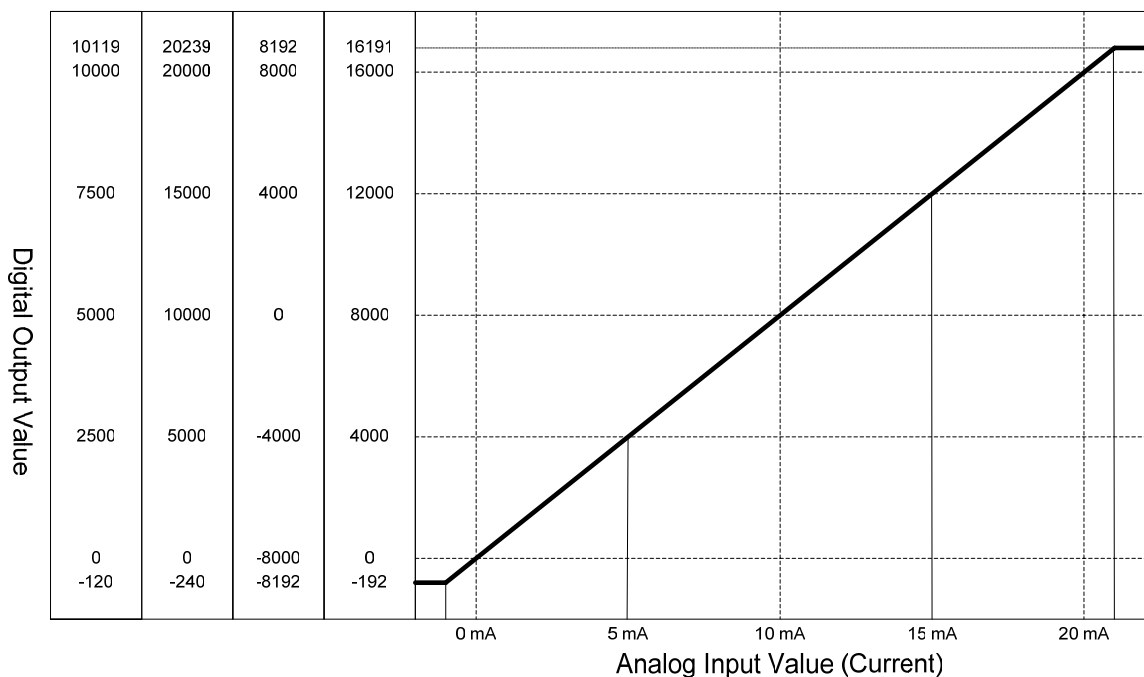
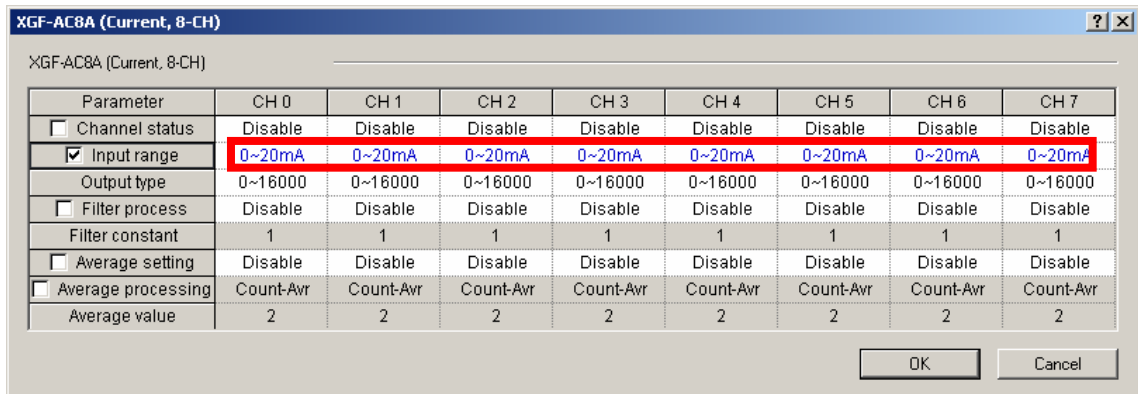

## Chapter 2 Specifications

- Digital output value for current input characteristics is as specified below.  
 (Resolution (based on 1/16000): 1.25  $\mu$ A)

Digital Output range	Analog input current (mA)						
	-0.24	0	5	10	15	20	20.23
Unsigned value (-192 ~ 16191)	-192	0	4000	8000	12000	16000	16191
Signed value (-8192 ~ 8191)	-8192	-8000	-4000	0	4000	8000	8191
Precise value (3808 ~ 20191)	-240	0	5000	10000	15000	20000	20239
Percentile value (-120 ~ 10119)	-120	0	2500	5000	7500	10000	10119

### Caution

- 1) If analog input value exceeding digital output range is input, the digital output value will be kept to be the max. or the min. value applicable to the output range specified. For example, if the digital output range is set to unsigned value (-192 ~ 16191) and the digital output value exceeding 16191 or analog value exceeding -192 is input, the digital output value will be fixed as 16191 or -192.
- 2) Voltage and current input shall not exceed  $\pm 15$  V and  $\pm 30$  mA respectively. Rising heat may cause defects.
- 3) Offset/Gain setting for XGF-AV8A/AC8A module shall not be performed by user.

### 2.4.3 Accuracy

Accuracy of digital output value does not change even if input range is changed. Fig. 2.1 shows the change range of the accuracy at ambient temperature of  $25 \pm 5 \text{ }^\circ\text{C}$  with analog input range of  $-10 \sim 10 \text{ V}$  selected and digital output type of Unsigned value selected.  $\pm 0.2\%$  of error tolerance is acceptable at ambient temperature of  $25 \pm 5 \text{ }^\circ\text{C}$ , and  $\pm 0.3\%$  at ambient temperature of  $0 \sim 55 \text{ }^\circ\text{C}$ .

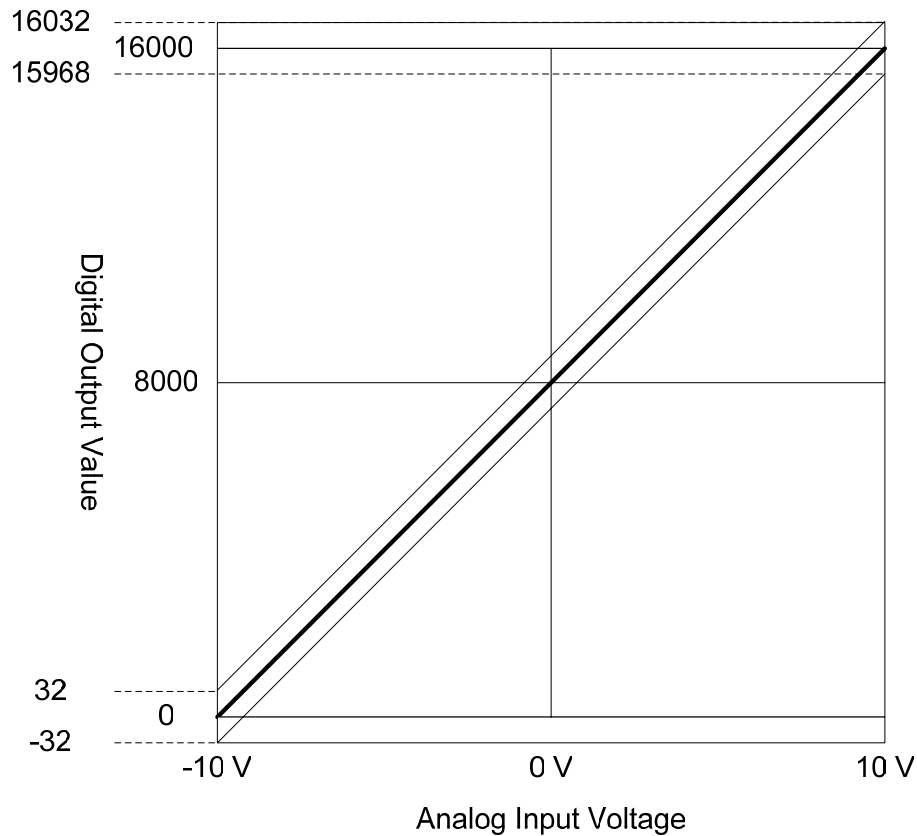

[Fig. 2.1] Accuracy

## 2.5 Functions of Analog Input Module

Functions of A/D conversion module are as described below in Table 2.3.

[Table 2.3] List of Functions

Function Item	Details
Channel Run/Stop setting	(1) Specify Run/Stop of the channel to execute A/D conversion. (2) If the unused channel is set to Stop, whole Run time can be reduced.
Input voltage/Current range setting	(1) Specify analog input range to be used. (2) 4 input ranges available for voltage type of module, and 2 input ranges for current type of module.
Output data format setting	(1) Specify digital output type. (2) 4 output data formats are provided in this module.
A/D conversion methods	(1) Sampling processing Sampling process will be performed if A/D conversion type is not specified. (2) Filter processing Used to delay the sudden change of input value. (3) Average processing Outputs average A/D conversion value based on frequency or time.
Function to detect input disconnected	(1) If analog input with the range of 1 ~ 5 V (4 ~ 20 mA) is disconnected, user program will detect it.

There are three A/D conversion methods, sampling processing, filter processing and average processing.

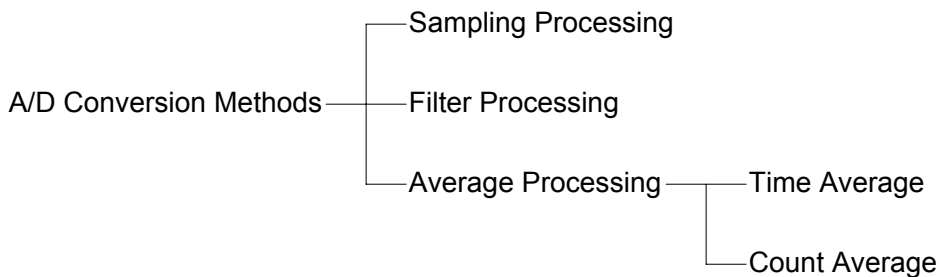

### 2.5.1 Sampling processing

It collects analog input sign through general A/D conversion processing at a specific interval so to convert to digital. The time required for A/D conversion of analog input sign till saved on the memory depends on the number of channels used.

$$\text{(Processing time)} = \text{(Number of Channels used)} \times \text{(Conversion speed)}$$

Ex.) If the number of channels used is 3, its process time will be  
 $(3) \times (250 \mu\text{s}) = 750 \mu\text{s}$

Sampling is to calculate the sampling value of continuous analog sign at a specific interval.

## 2.5.2 Filter processing

Filter process function is used to obtain stable digital output value by filtering (delaying) noise or sudden change of input value. Filter constant can be specified for respective channels through user program or I/O parameters setting.

- Setting range: 1 ~ 99 (%)

$$F[n] = (1 - \alpha) \times A[n] + \alpha \times F[n - 1]$$

$F[n]$ : Present filter output value  
 $A[n]$ : Present A/D converted value  
 $F[n-1]$ : Previous filter output value  
 $\alpha$ : Filter constant (0.01 ~ 0.99: Previous value added)

- \*1 If filter setting value is not specified within 1 ~ 99, RUN LED blinks at an interval of 1 second. In order to set RUN LED to On status, reset the filter setting value within 1 ~ 99 and then convert PLC CPU from STOP to RUN. Be sure to use request flag of error clear (UXY.11.0) to clear the error through modification during RUN.
- \*2 If any error occurs in filter setting value, the default of filter setting value 1 will be saved.

### 1) In the case of XGF-AV8A

- Analog input range: DC -10 ~ 10 V, Digital output range: 0 ~ 16000.
- If analog input value changes -10 V → 10 V (0 → 16000), filter output value based on  $\alpha$  value is as specified below.

$\alpha$ value	Filter output value			Remarks	
	1 scan	2 scan	3 scan		
*1) 0.01	0	15840	15998	15999	1% inclined toward previous value
*2) 0.5	0	8000	12000	14000	50% inclined toward previous value
*3) 0.99	0	160	318	475	99% inclined toward previous value

\*1) 16000 output after about 4 scans

\*2) 16000 output after about 22 scans

\*3) 16000 output after about 1491 scans (372.75 ms for 1 channel Run)

### 2) In the case of XGF-AC8A

- Analog input current range: DC 0 ~ 20 mA, Digital output range: 0 ~ 16000.
- If analog input value changes 0 mA → 10 mA (0 → 8000), filter output value based on  $\alpha$  value is as specified below.

$\alpha$ value	Filter output value			Remarks	
	1 scan	2 scan	3 scan		
*1) 0.01	0	7920	7999	7999	1% inclined toward previous value
*2) 0.5	0	4000	6000	7000	50% inclined toward previous value
*3) 0.99	0	80	159	237	99% inclined toward previous value

\*1) 8000 output after about 4 scans

\*2) 8000 output after about 21 scans

\*3) 8000 output after about 1422 scans (355.5 ms for 1 channel Run)

- If filter process function is not used, present A/D converted value will be output as it is. The filter process function takes value-added data between 'Present A/D converted value' and 'Previous A/D converted value'. And the value-added data can be decided with filter constant. If output data shakes too much, set a big filter constant value.

### 2.5.3 Average processing

This process is used to execute A/D conversion of the channel designated for specified frequency or for specified time and save the average of the accumulated sum on memory. Average processing option and time/frequency value can be defined through user program or I/O parameters setting for respective channels.

1) What is the average processing used for

This process is used for A/D conversion of abnormal analog input sign such as noise to a value near to normal analog input sign.

2) Average processing type

Average processing type is of time average and count average.

(1) Time average processing

A) Setting range: 4 ~ 16000 (ms)

B) Average processing count within specified time is decided based on the number of channels used.

$$\text{Average processing count} = \frac{\text{Setting time}}{(\text{Number of Channels used}) \times (\text{Conversion Speed})}$$

Ex.1) Channels used: 1, setting time: 16000 ms

$$\text{Average processing count} = \frac{16000 \text{ ms}}{1 \times 0.25 \text{ ms}} = 64000 \text{ times}$$

Ex.2) Channels used: 8, setting time: 4 ms

$$\text{Average processing count} = \frac{4 \text{ ms}}{8 \times 0.25 \text{ ms}} = 2 \text{ times}$$

\*1: If setting value of time average is not specified within 4 ~ 16000, RUN LED blinks at an interval of 1 second. In order to set RUN LED to On status, reset the setting value of time average within 4 ~ 16000 and then convert PLC CPU from STOP to RUN. Be sure to use request flag of error clear (UXY.11.0) to clear the error through modification during RUN.

\*2: If any error occurs in setting value of time average, the default value 4 will be saved.

- C) Time average is processed after converted to average of the times inside the A/D conversion module. In this case, a remainder may be produced when setting time is divided by (number of channels used X conversion speed), which will be disregarded. Thus, the average processing frequency will be the quotient of [(setting time) ÷ (number of channels used x conversion speed)].

Ex.) If the number of channels used is 5, and setting time is 151 ms.  
 $151 \text{ ms} \div (5 \times 0.25 \text{ ms}) = 120 \text{ times} \dots\dots \text{Remainder of } 8 \rightarrow 120 \text{ times}$

(2) Count average process

- A) Setting range: 2 ~ 64000 (times)  
 B) The time required for average value to be saved on memory when frequency average used depends on the number of channels used.  
 Process time = setting frequency X number of channels used X conversion speed

\*1: If setting value of count average is not specified within 2 ~ 64000, RUN LED blinks at an interval of 1 second. In order to set RUN LED to On status, reset the setting value of frequency average within 2 ~ 64000 and then convert PLC CPU from STOP to RUN. Be sure to use request flag of error clear (UXY.11.0) to clear the error through modification during RUN..

\*2: If any error occurs in setting value of frequency average, the default value 2 will be saved.

Ex.) If the number of channels used is 4, and average processing frequency is 50.  
 $50 \times 4 \times (0.25 \text{ ms}) = 50 \text{ ms}$

**2.5.4 Input disconnection detection function**

1) Input range available

If the input sign range of 1 ~ 5 V (4 ~ 20 mA) is used, the function to detect input circuit disconnected will be available. Detection conditions for respective input sign ranges are as described below in the table.

Input signal range	Voltage/Current value regarded as disconnected
1 ~ 5 V	0.2 V or less
4 ~ 20 mA	0.8 mA or less

2) Disconnection display for respective channels

Detection sign of disconnection for respective input channels will be saved on UXY. 10. (X stands for Base No., and Y for Slot No.)

Bit	15	14	13	12	11	10	9	8	7	6	5	4	3	2	1	0
Default	0	0	0	0	0	0	0	0	0	0	0	0	0	0	0	0
Assigned	-	-	-	-	-	-	-	-	CH	CH	CH	CH	CH	CH	CH	CH
									7	6	5	4	3	2	1	0

BIT	Description
0	Normal
1	Disconnected

## Chapter 2 Specifications

### 3) Operation

Each bit will be set to 1 if an assigned channel is detected as disconnected, and back to 0 if connected back. In addition, each bit can be used to detect the disconnection in the user program together with execution conditions.

### 4) Program Example

If a module is installed on Base No.0 and Slot No.2 with detection flag of disconnection used, it will be as shown below. If the applicable channel is detected as disconnected, the channel number detected will be written on the P area.

(System configuration)

XGP-ACF2	XGK-CPUS			XGF-AV8A	
----------	----------	--	--	----------	--

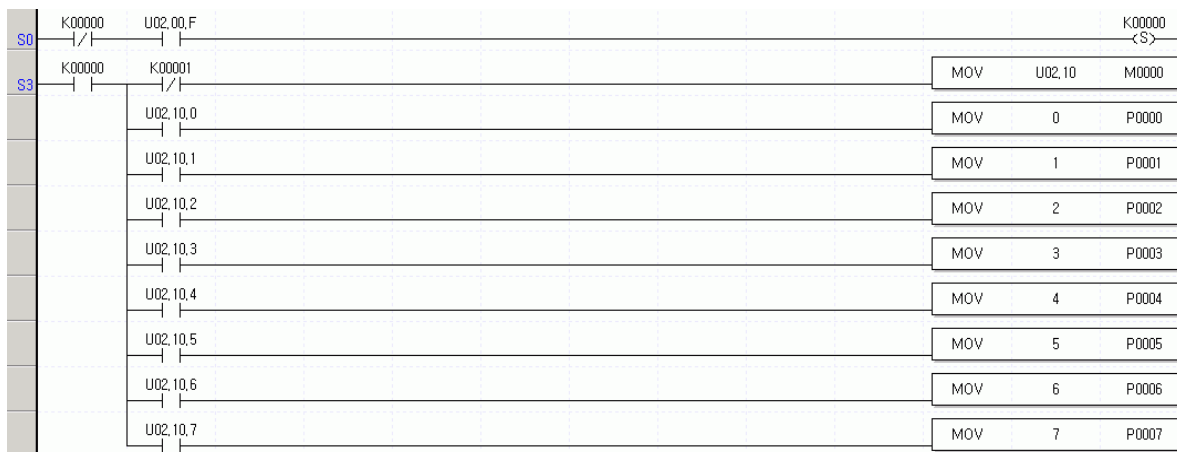

# Chapter 3 Installation and Wiring

## 3.1 Installation

### 3.1.1 Installation environment

This product is of high reliance regardless of installation environment. However, for the sake of reliance and stability of the system, please pay attention to those precautions described below.

- 1) Environmental conditions
  - To be installed on the control panel waterproof and dustproof.
  - No continuous impact or vibration shall be expected.
  - Not to be exposed to the direct sunlight.
  - No dew shall be caused by rapid temperature change.
  - Ambient temperature shall be kept 0-55°C.
  
- 2) Installation work
  - No wiring waste is allowed inside PLC when wiring or drilling screw holes.
  - To be installed on a good location to work on.
  - Don't let it installed on the same panel as a high-voltage device is on.
  - Let it kept at least 50mm away from duct or near-by module.
  - To be grounded in an agreeable place free from noise.

### 3.1.2 Precautions for handling

Precautions for handling A/D conversion module are as described below from the opening to the installation.

- 1) Don't let it dropped or shocked hard.
- 2) Don't remove PCB from the case. It will cause abnormal operation
- 3) Don't let any foreign materials including wiring waste inside the top of the module when wiring. Remove foreign materials if any inside.
- 4) Don't install or remove the module while powered on.

**3.2 Wiring**

**3.2.1 Precautions for wiring**

- 1) Don't let AC power line near to A/D conversion module's external input sign line. With an enough distance kept away between, it will be free from surge or inductive noise.
- 2) Cable shall be selected in due consideration of ambient temperature and allowable current, whose size is not less than the max. cable standard of AWG22 (0.3mm<sup>2</sup>).
- 3) Don't let the cable too close to hot device and material or in direct contact with oil for long, which will cause damage or abnormal operation due to short-circuit.
- 4) Check the polarity when wiring the terminal.
- 5) Wiring with high-voltage line or power line may produce inductive hindrance causing abnormal operation or defect.

**3.2.2 Wiring examples**

- 1) XGF-AV8A

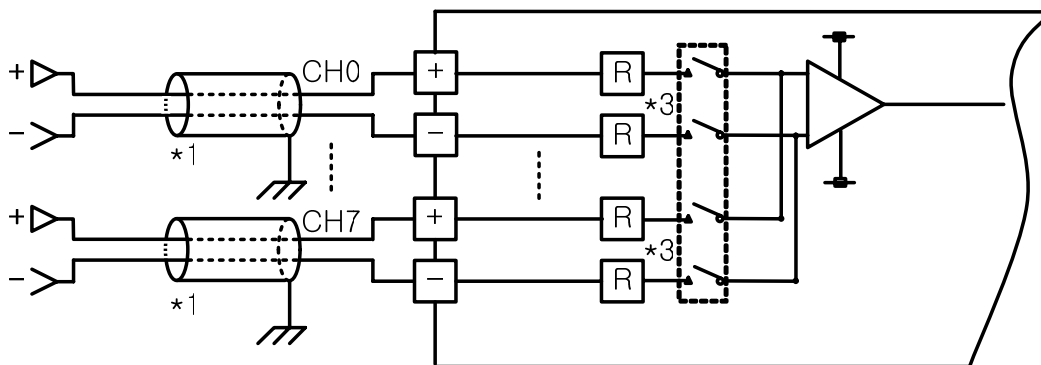

- 2) XGF-AC8A

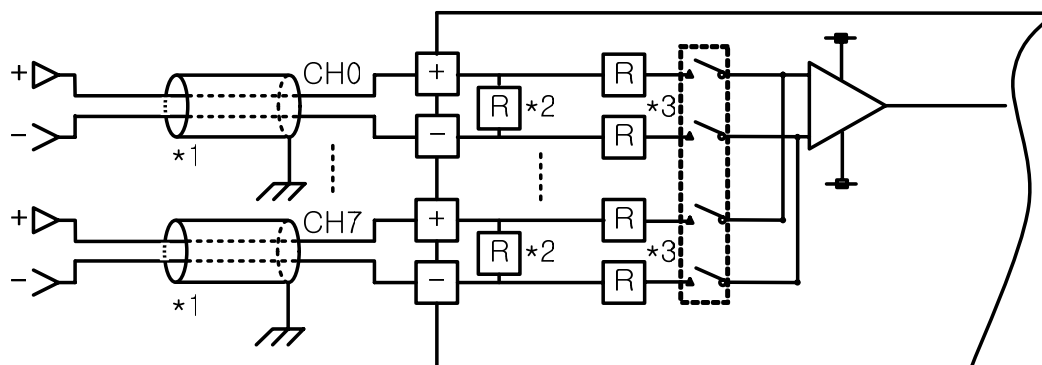

\*1) Use a 2-core twisted shielded wire. AWG 22 is recommended for the cable standard.  
 \*2) XGF-AC8A's input resistance is 250 Ω (typ.).  
 \*3) XGF-AV8A's input resistance is 1 MΩ (min.).

3) Wiring example of 2-wire sensor/transmitter (current input)

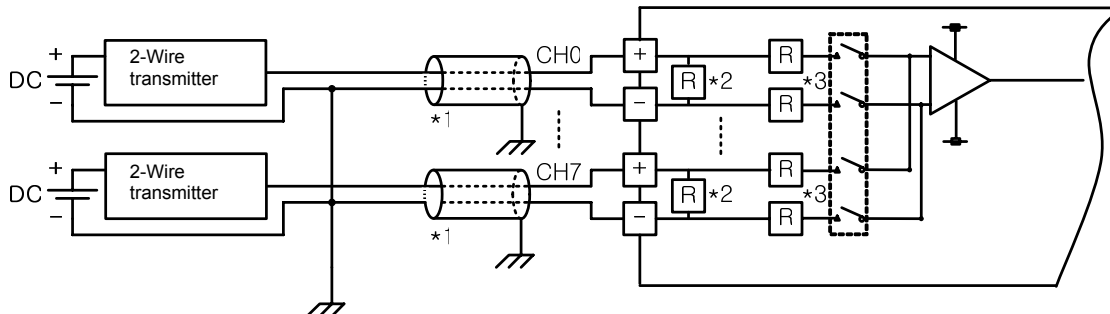

- Run the channel to be used only.
- Analog input module does not provide power for the input device. Use an external power supplier.

4) Wiring example of 4-wire sensor/transmitter (voltage/current input)

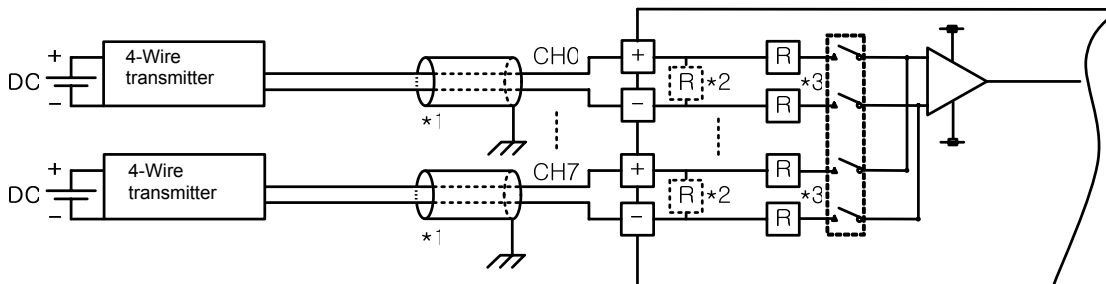

- Start the channel to be used only.
- Analog input module does not provide power for the input device. Use an external power supplier.

\* 1) Use a 2-core twisted shielded wire. AWG 22 is recommended for the cable standard.  
 \* 2) XGF-AC8A's input resistance is 250 Ω (typ.).  
 \* 3) XGF-AV8A's input resistance is 1 MΩ (min.).

## Chapter 3 Installation and Wiring

### 5) Relationship between voltage input accuracy and wiring length

In voltage input, the wiring (cable) length between transmitter or sensor and module has an effect on digital-converted values of the module as specified below;

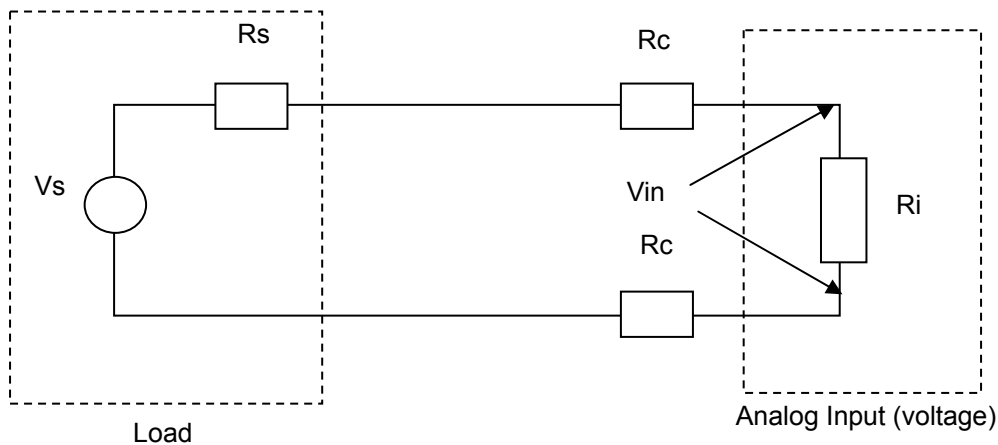

Where,

$R_c$ : Resistance value due to line resistance of cable

$R_s$ : Internal resistance value of transmitter or sensor

$R_i$ : Internal resistance value ( $1M\Omega$ ) of voltage input module

$V_{in}$ : Voltage allowed to analog input module

%  $V_i$ : Tolerance of converted value (%) due to source and cable length in voltage input

$$V_{in} = \frac{R_i \times V_s}{[R_s + (2 \times R_c) + R_i]}$$

$$\% V_i = \left(1 - \frac{V_{in}}{V_s}\right) \times 100 \%$$

### Notes

In current input, there will be no accuracy tolerance caused by cable length and internal resistance of the source.

## Chapter 4 Operation Procedures and Monitoring

### 4.1 Operation Procedures

The processing for the operation is as shown in Fig. 4.1.

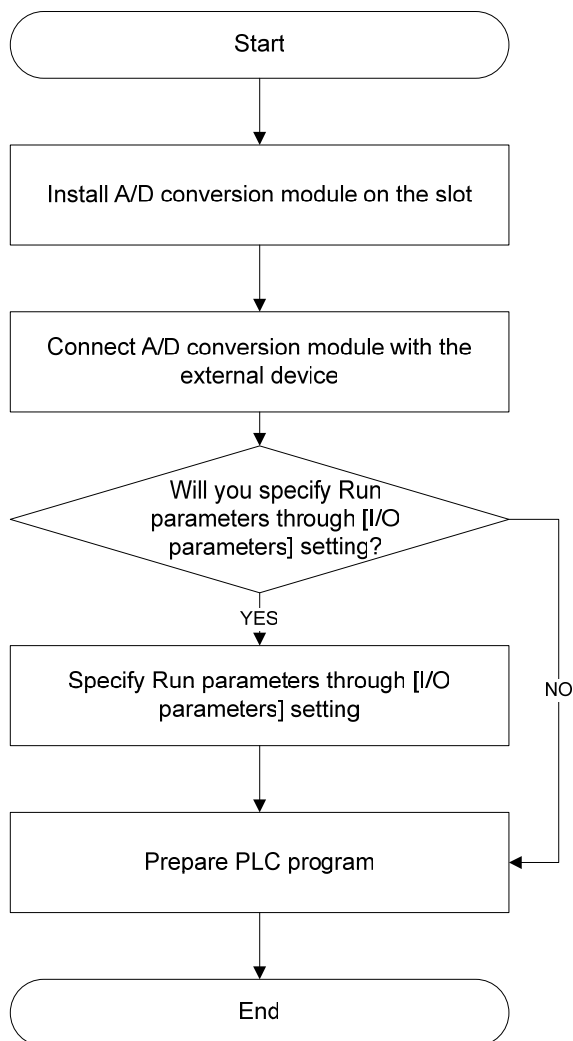

[Fig. 4. 1] Procedures for the operation

# Chapter 4 Operation Procedures and Monitoring

## 4.2 Operation Parameters Setting

A/D conversion module's operation parameters can be specified through XG5000's [I/O parameters].

### 4.2.1 Settings

For the user's convenience of A/D conversion module, XG5000 provides GUI (Graphical User Interface) for parameters setting of A/D conversion module. Setting items available through [I/O parameters] on the XG5000 project window are as described below in the table 4.1.

[Table 4. 1] Function of [I/O Parameters]

Item	Details
[I/O parameters]	<p>(1) Specify the following setting items necessary for the module operation.</p> <ul style="list-style-type: none"> <li>- Channel Enable/Disable setting</li> <li>- Setting ranges of input voltage/current</li> <li>- Output data format setting</li> <li>- Filter processing Enable/Disable setting</li> <li>- Filter constant setting</li> <li>- Average processing Enable/Disable setting</li> <li>- Average processing method setting</li> <li>- Average value setting</li> </ul> <p>(2) The data specified by user through S/W package will be saved on A/D conversion module when [Special Module Parameters] are downloaded. In other words, the point of time when [Special Module Parameters] are saved on A/D conversion module has nothing to do with PLC CPU's status RUN or SPOP.</p>

### 4.2.2 I/O parameters

How to use [I/O parameters] will be described below as based on XGF-AV8A. Sequence of XGF-AC8A to use is also as identical as specified below.

- 1) Run XG5000 to create a project. (Refer to XG5000 program manual for details on how to create the project)
- 2) Double-click [I/O parameters] on the project window.

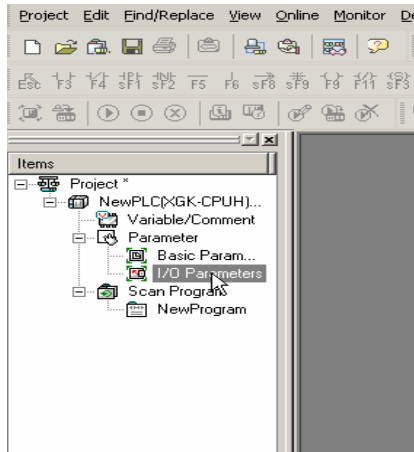

## Chapter 4 Operation Procedures and Monitoring

- 3) On the 'I/O parameters setting' screen, find and click the slot of the base A/D conversion module is installed on. 8-channel voltage type of A/D conversion module is installed on Base No.0, Slot No.4 in this description.

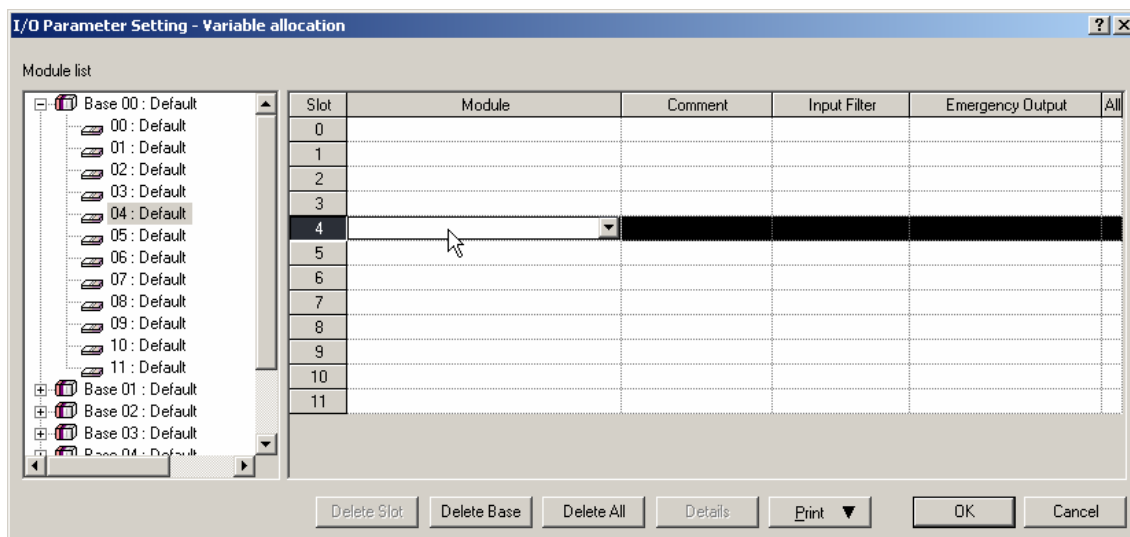

- 4) Click the arrow button on the screen above to display the screen where an applicable module can be selected. Search for the applicable module to select.

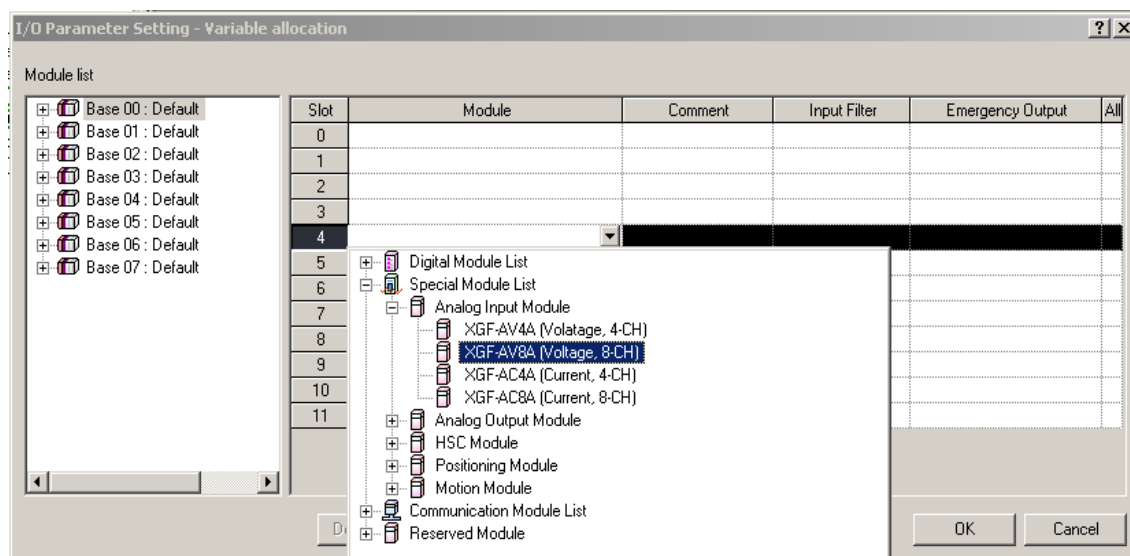

# Chapter 4 Operation Procedures and Monitoring

5) After the module selected, click [Details].

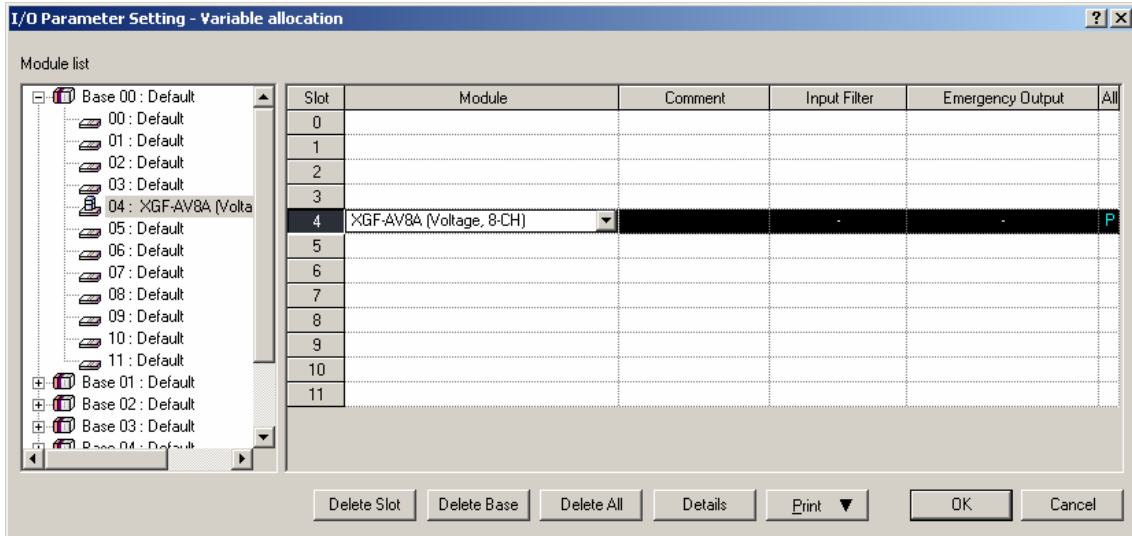

6) A screen will be displayed for you to specify parameters for respective channels as shown below. Click a desired item to display parameters to set for respective items.

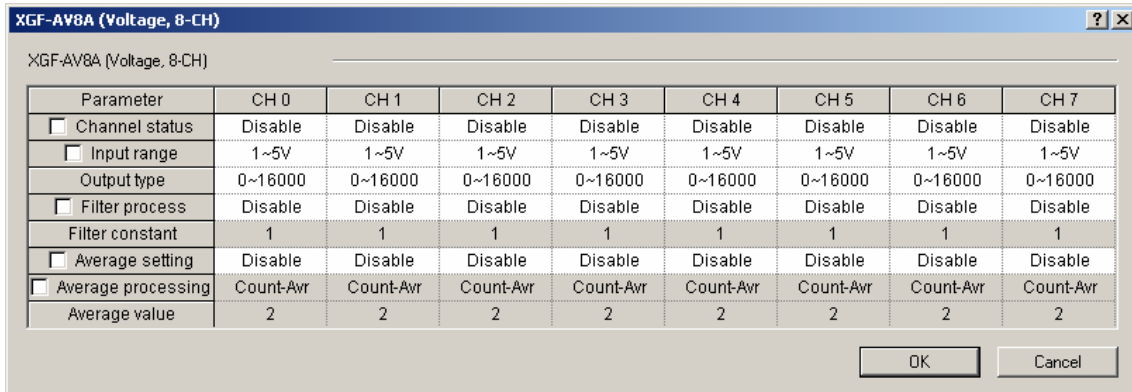

(1) Channel status: Select Disable or Enable.

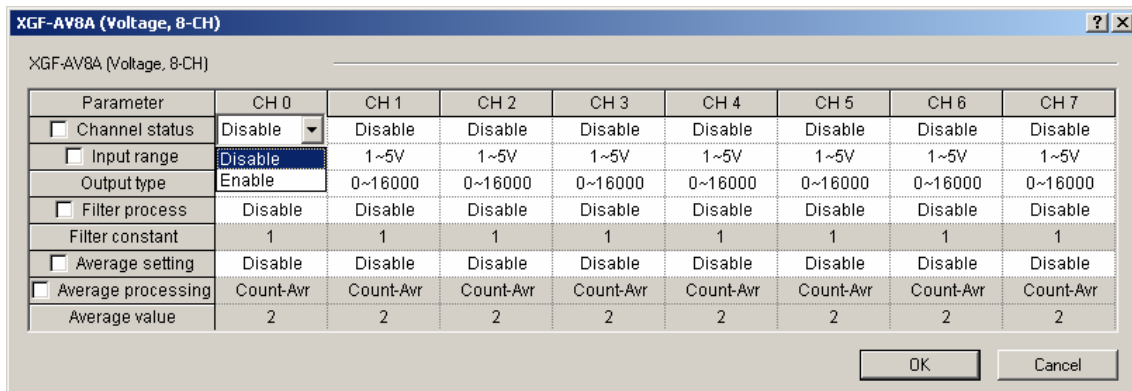

## Chapter 4 Operation Procedures and Monitoring

- (2) Input range: Select the range of analog input voltage as desired. XGF-AV8A provides 4 voltage input ranges, and XGF-AC8A provides 2 current input ranges.

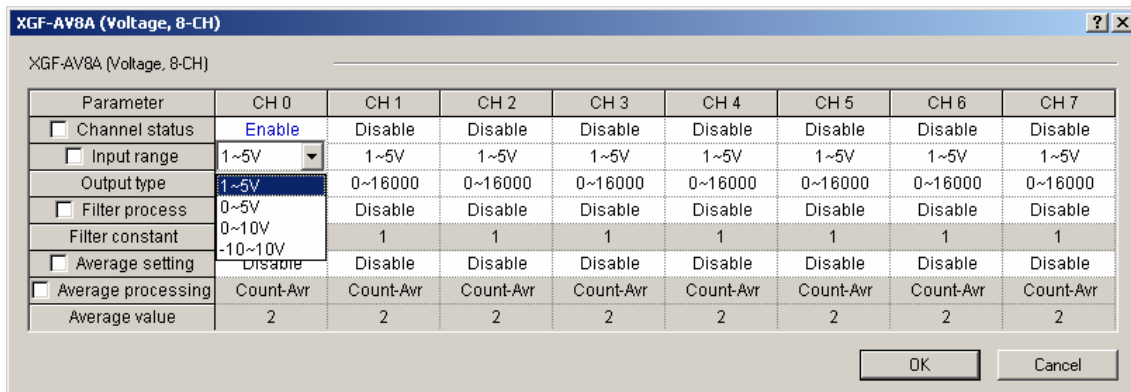

- (3) Output type: Select the type of output data. 4 formats are available in total.

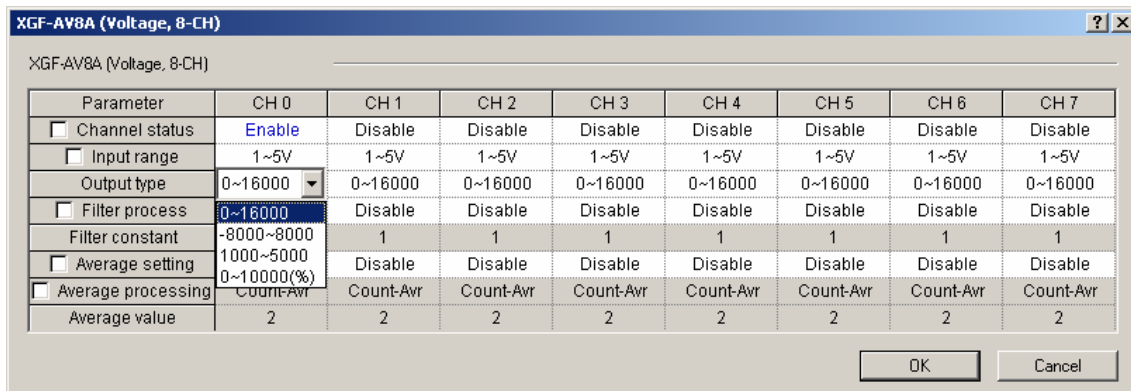

- (4) Filter process: Set the filter process to Enable or Disable.

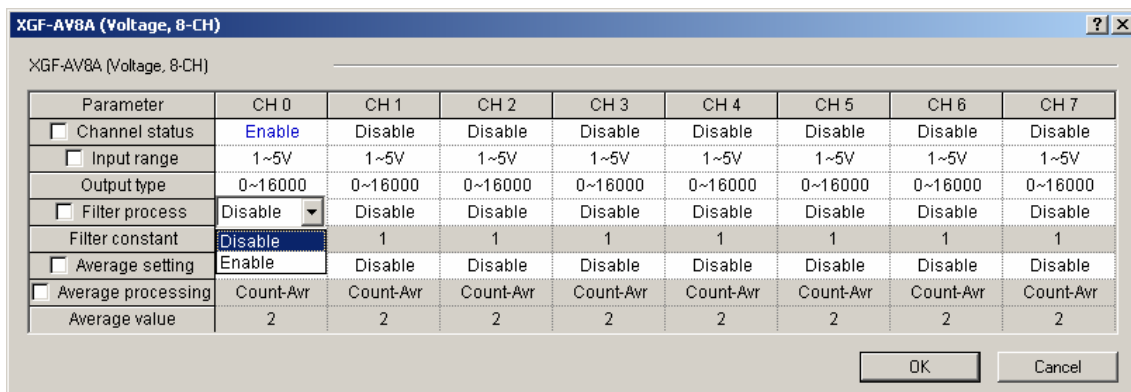

# Chapter 4 Operation Procedures and Monitoring

- (5) Filter constant: Set the filter process above surely to [Enable] in order to input the filter constant in this field. With the filter process set to [Enable], double-click the value of the filter constant to input the value. The range of the value available in this field is 1 ~ 99. Any value exceeding this range will not be input.

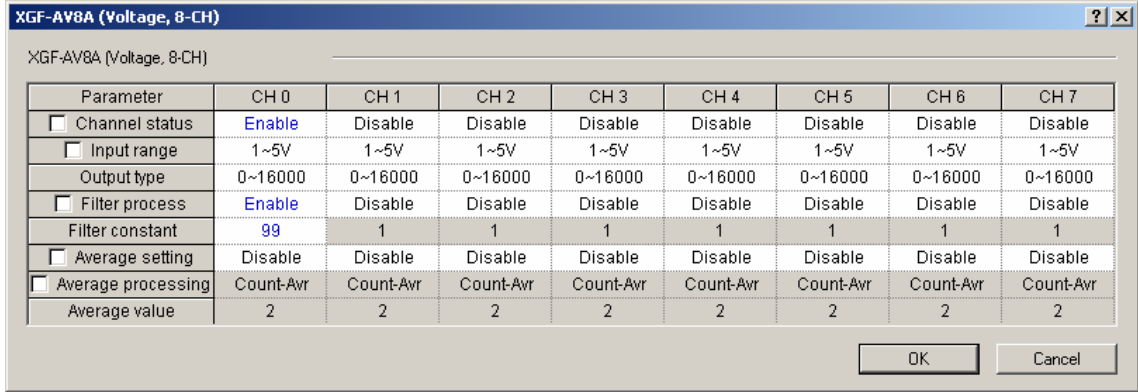

- (6) Average setting: Set the average setting to Enable or Disable.

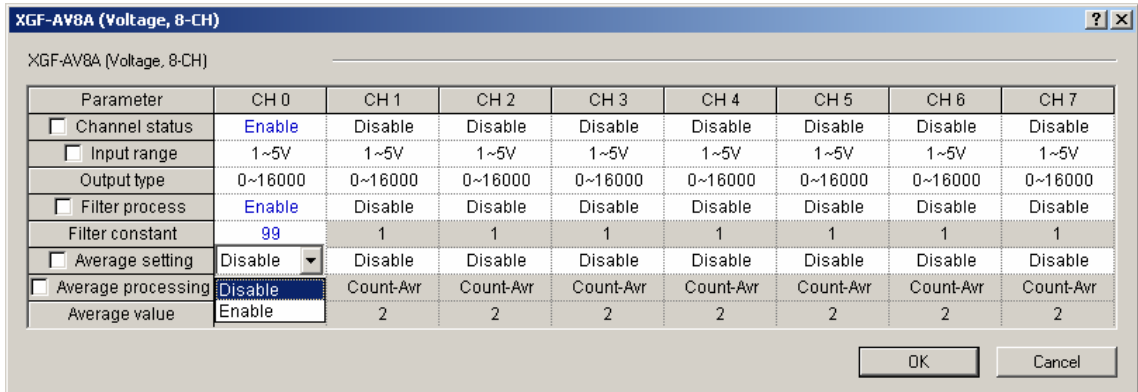

- (7) Average processing: Set the average processing above surely to [Enable] in order to change the value in this field. Average processing can be selected between time average and count average.

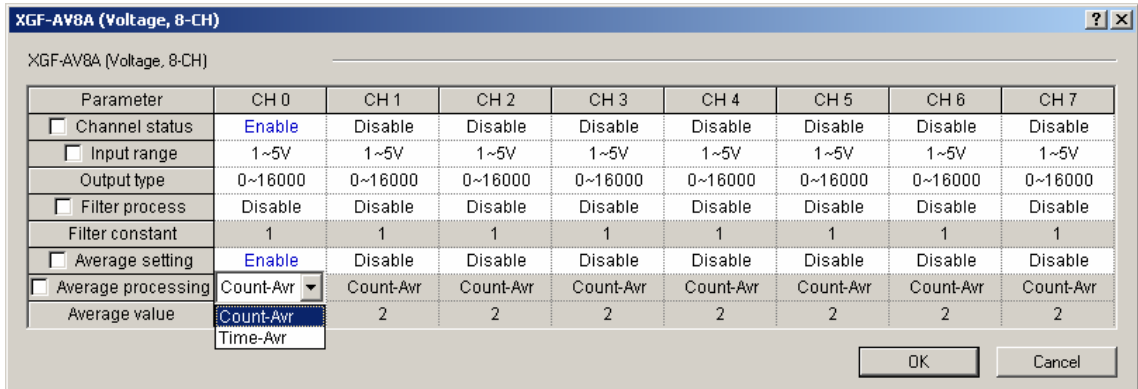

## Chapter 4 Operation Procedures and Monitoring

- (8) Average value: Set the average process above surely to [Enable] in order to input the average value in this field. With the average process set to [Enable], double-click the average value to input the value. The range of the value available in this field is 2 ~ 64000 for frequency average, and 4 ~ 16000 for time average. Any value exceeding this range will not be input

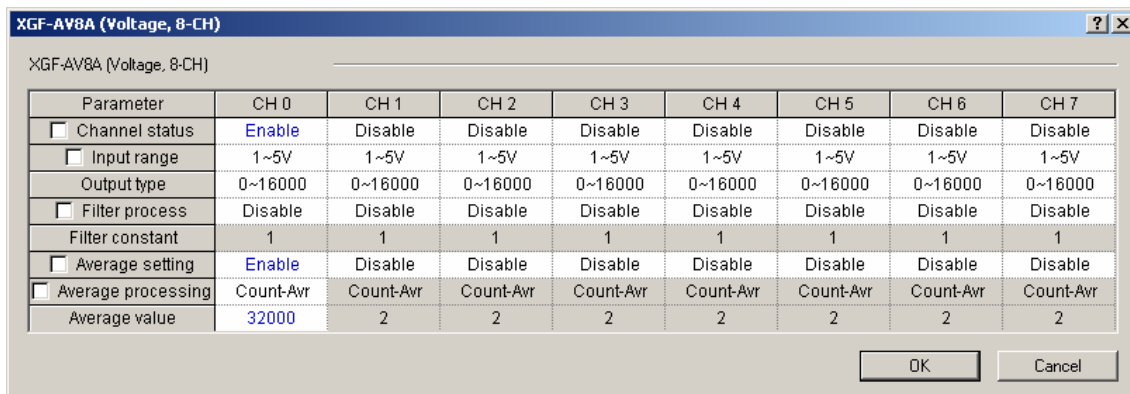

7) How to select the whole channels to change parameters

Click and check the radio button in the parameters item in order to change the whole channels to identical setting value. And then change the parameters of an optional channel to change the parameters of the whole channels at a time. Fig. 4.2 shows an example that Run channel is changed to whole channels 'Enable' by means of this function.

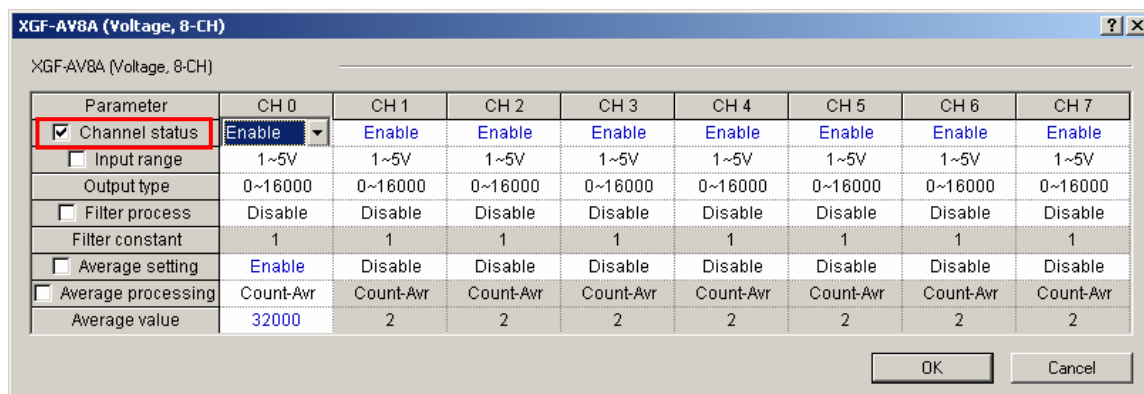

[Fig. 4. 2] Parameters change of the whole channels

### 4.3 Special Module Monitoring Functions

Functions of Special Module Monitoring are as described below in table 4.2.

[Table 4. 2] Functions of Special Module Monitoring

Item	Details	Remarks
[Special Module Monitoring]	(1) Monitor/Test Through applicable XG5000 menu of [Monitor] -> [Special Module Monitoring], A/D converted value can be monitored and the operation of A/D conversion module can be tested.  (2) Monitoring the max./min. value The max./min. value of the channel can be monitored during Run. However, the max./min. value displayed here is based on the present value shown on the screen. Accordingly, when [Monitoring/Test] screen is closed, the max./min. value will not be saved.	

#### Notes

The screen may not be normally displayed due to insufficient system resource. In such a case, close the screen and finish other applications in order to restart XG5000.

### 4.4 Precautions

- The parameters specified for the test of A/D conversion module on the “Monitor Special Module” screen of [Monitor Special Module] will be deleted the moment the “Monitor Special Module” screen is closed. In other words, the parameters of A/D conversion module specified on the “Monitor Special Module” screen will not be saved in [I/O parameters] located on the left tab of XG5000.

The screenshot shows the 'Monitor Special Module' window for XGF-AV8A (Voltage, 8-CH). It contains two tables and several buttons.

Item	Max/Min Value	Current Value
CH0 A/D Value	8000 / 7999	8000
CH1 A/D Value	0 / 0	0
CH2 A/D Value	0 / 0	0
CH3 A/D Value	0 / 0	0
CH4 A/D Value	0 / 0	0
CH5 A/D Value	0 / 0	0
CH6 A/D Value	0 / 0	0
CH7 A/D Value	0 / 0	0

Item	Setting Value	Current Value
Channels	CH 0	
Channel Status	Enable	Enable
Input Range	-10~10V	-10~10V
Output Type	0~16000	0~16000
Filter Process	Disable	Disable
Filter Constants	1	1
Average Process	Disable	Disable
Average Method	Count-Avr	Count-Avr
Average Value	2	2

Buttons: Reset max/min value, Stop Monitoring, Test, Close.

An arrow points from a circled 'Current Value' column in the settings table to a text box: "Not saved in [I/O parameters]."

- Test function of [Monitor Special Module] is provided for user to check the normal operation of A/D conversion module even without sequence programming. If A/D conversion module is to be used for other purposes than a test, use parameters setting function in [I/O parameters].

## 4.5 Special Module Monitoring

Monitoring special module will be based on XGF-AV8A. Sequence of XGF-AC8A to use is as identical as specified below.

### 4.5.1 Start of [Special Module Monitoring]

Go through [Online] -> [Connect] and [Monitor] -> [Special Module Monitoring] to start. If the status is not [Online], [Special Module Monitoring] menu will not be active.

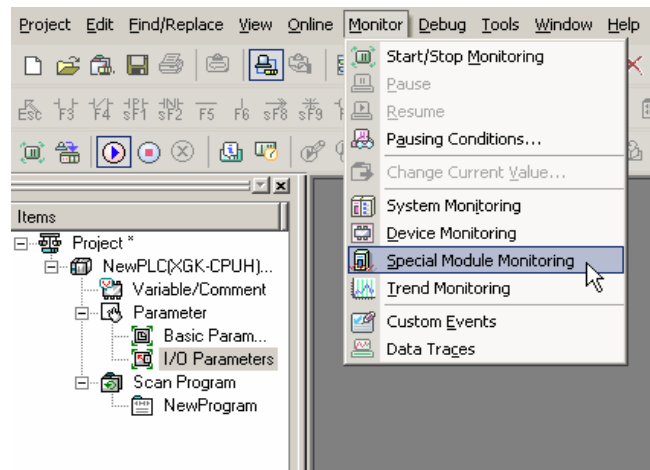

### 4.5.2 How to use [Special Module Monitoring]

- 1) With XG5000 connected to PLC CPU (on-line status), click [Monitor] -> [Special Module Monitoring] to display 'Special Module List' screen as in Fig. 5.1 showing base/slot information in addition to special module type. The module installed on the present PLC system will be displayed on the list dialog box.

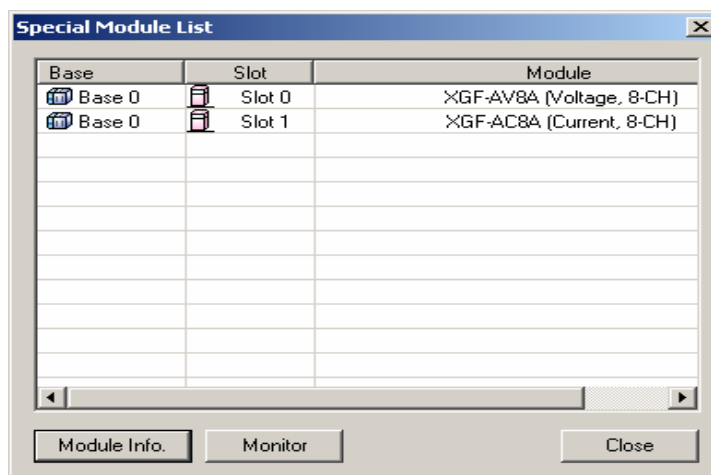

[Fig. 5. 1] Screen of [Special Module List]

- 2) Select Special Module in Fig. 5.1 and click [Module Information] to display the information as in Fig. 5.2.

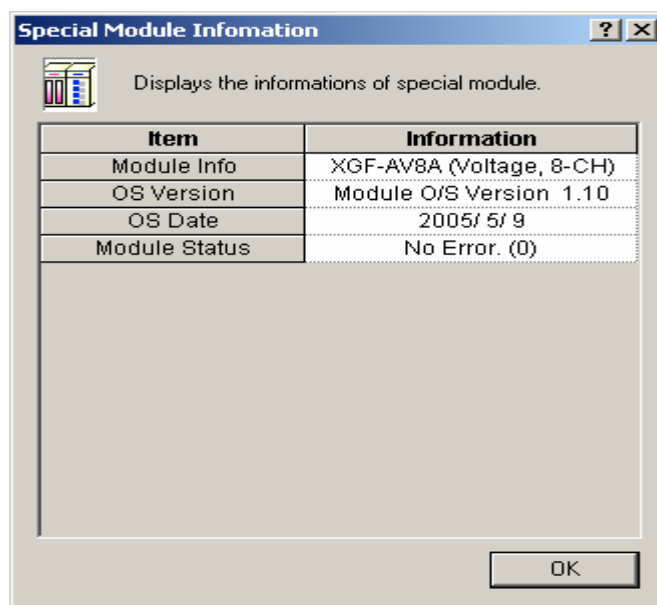

[Fig. 5. 2] Screen of [Special Module Information]

- 3) Click [Monitor] on the “Special Module” screen in Fig. 5.1 to display [Special Module Monitoring] screen as in Fig. 5.3, where 4 options are available such as [Reset max./min. value], [Start Monitoring], [Test] and [Close]. A/D conversion module’s output value and max./min. value are displayed on the monitoring screen at the top of the screen, and parameters items of respective modules are displayed for individual setting on the test screen at the bottom of the screen.

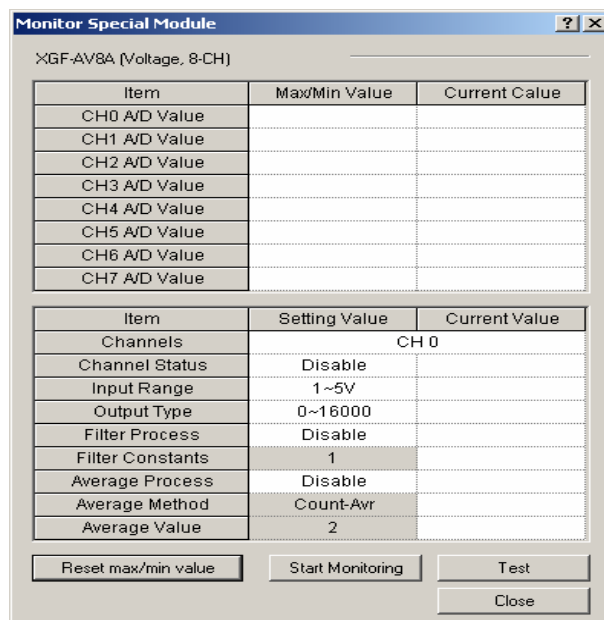

[Fig. 5. 3] [Special Module Monitoring] screen

- (1) [Start Monitoring]: Click [Monitor Start] to display A/D converted value of the presently operated channel. Fig. 5.4 is the monitoring screen displayed when the whole channels of XGF-AV8A are in Stop status. In the present value field at the screen bottom, presently specified parameters of A/D conversion module are displayed.

# Chapter 4 Operation Procedures and Monitoring

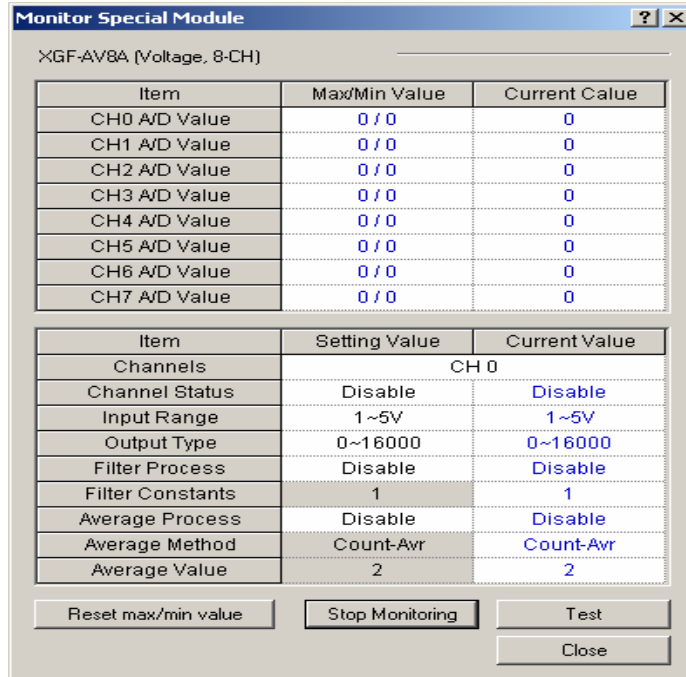

[Fig. 5. 4] Execution screen of [Start Monitoring]

- (2) [Test]: [Test] is used to change the presently specified parameters of A/D conversion module. Click the setting value at the bottom field of the screen to change parameters. Fig. 5.5 will be displayed after [Test] is executed with channel 0's input voltage range changed to -10 ~ 10 V in the state of input not wired.

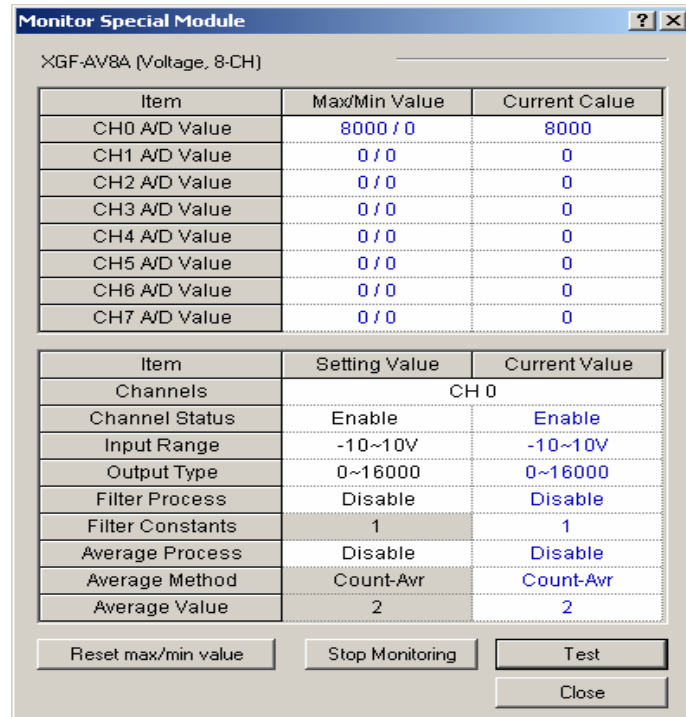

[Fig. 5. 5] Execution screen of [Test]

## Chapter 4 Operation Procedures and Monitoring

- (3) [Reset Max./Min. value]: The max./min. value field at the upper screen shows the max. value and the min. value of A/D converted value. Click [Reset max./min. value] to initialize the max./min. value. Fig.5.6 is after [Reset max./min. value] button is clicked in the Fig. 5.5, where channel 0's A/D converted value can be checked as reset.

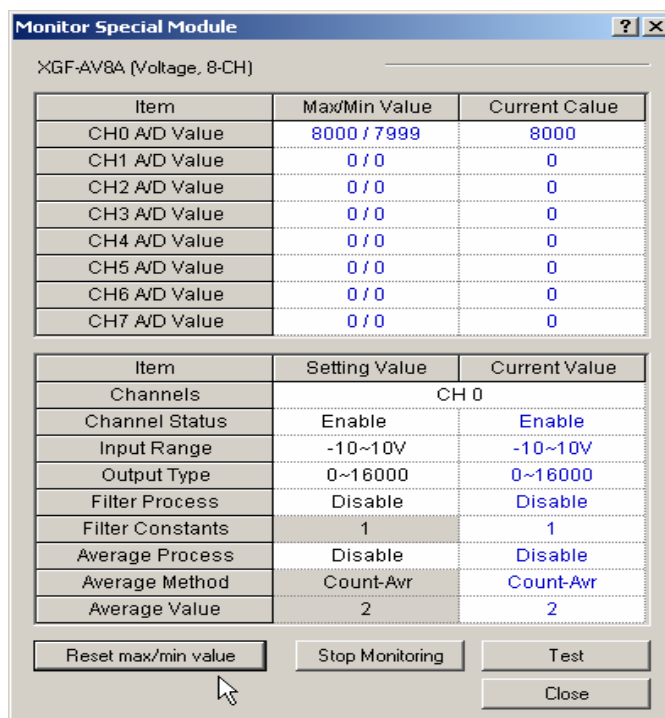

[Fig. 5. 6] Execution screen of [Reset max./min. value]

- (4) [Close]: [Close] is used to escape from the monitoring/test screen. When the monitoring/test screen is closed, the max. value, the min. value and the present value will not be saved any more.

# Chapter 4 Operation Procedures and Monitoring

## 4.6 Register U Devices

This section describes the automatic registration function of the U device in the XG5000

### 4.6.1 Register U devices

Register the variables for each module referring to the special module information that is set in the I/O parameter. The user can modify the variables and comments.

[Procedure]

- 1) Select the special module type in the [I/O parameter setting] window.

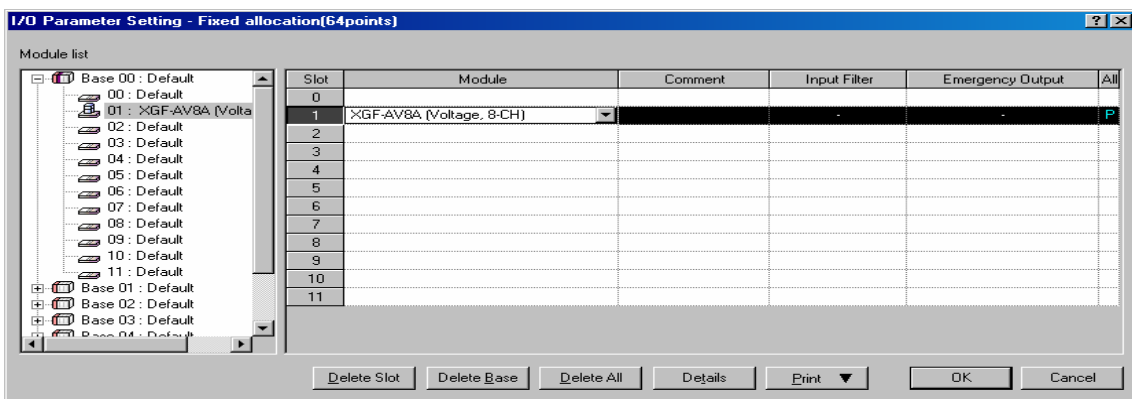

- 2) Double click 'Variable/Comment' from the project window.

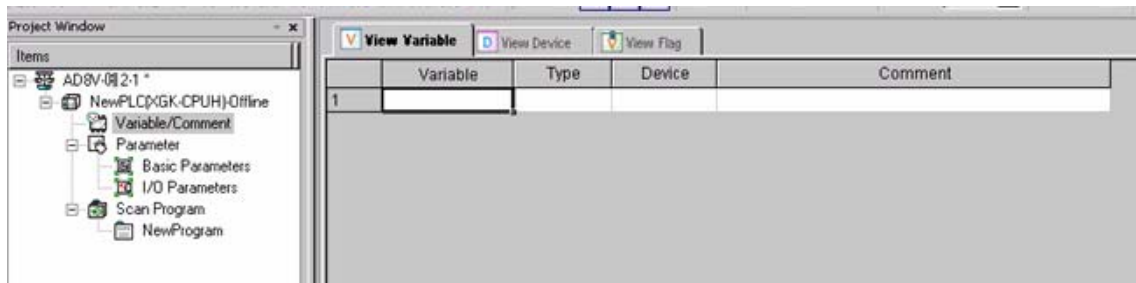

- 3) Select [Edit] -> [Register U Device].

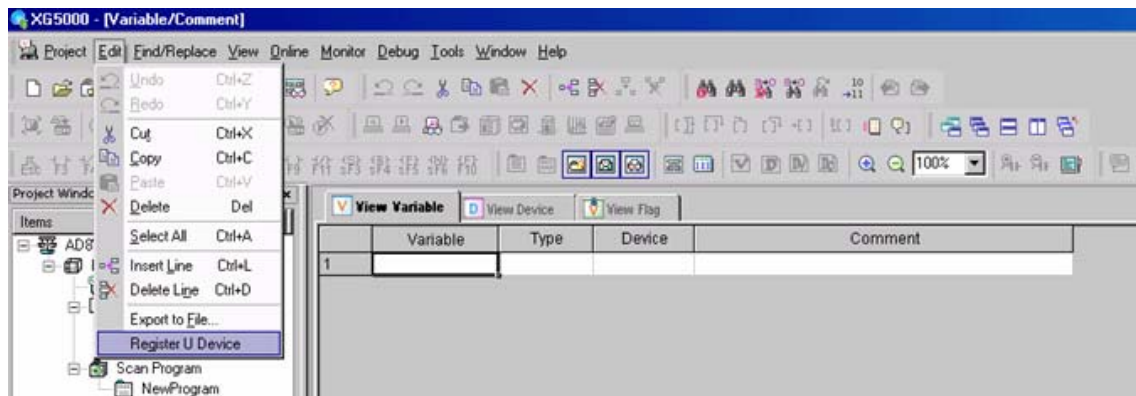

4) Click 'Yes'

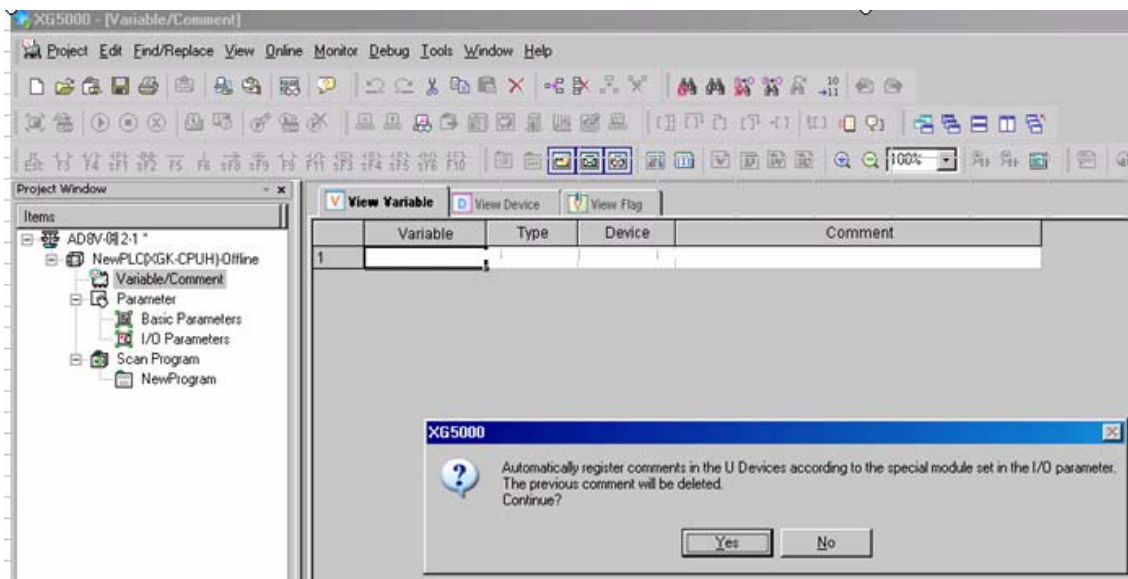

5) As shown below, the variables are registered.

	Variable	Type	Device	Comment
1	_01_RDY	BIT	U01.00.F	Analog Input Module: Module Ready
2	_01_CH0_ACT	BIT	U01.01.0	Analog Input Module: CH0 Active
3	_01_CH1_ACT	BIT	U01.01.1	Analog Input Module: CH1 Active
4	_01_CH2_ACT	BIT	U01.01.2	Analog Input Module: CH2 Active
5	_01_CH3_ACT	BIT	U01.01.3	Analog Input Module: CH3 Active
6	_01_CH4_ACT	BIT	U01.01.4	Analog Input Module: CH4 Active
7	_01_CH5_ACT	BIT	U01.01.5	Analog Input Module: CH5 Active
8	_01_CH6_ACT	BIT	U01.01.6	Analog Input Module: CH6 Active
9	_01_CH7_ACT	BIT	U01.01.7	Analog Input Module: CH7 Active
10	_01_CH0_IDD	BIT	U01.10.0	Analog Input Module: CH0 Input Disconnection Flag
11	_01_CH1_IDD	BIT	U01.10.1	Analog Input Module: CH1 Input Disconnection Flag
12	_01_CH2_IDD	BIT	U01.10.2	Analog Input Module: CH2 Input Disconnection Flag
13	_01_CH3_IDD	BIT	U01.10.3	Analog Input Module: CH3 Input Disconnection Flag
14	_01_CH4_IDD	BIT	U01.10.4	Analog Input Module: CH4 Input Disconnection Flag
15	_01_CH5_IDD	BIT	U01.10.5	Analog Input Module: CH5 Input Disconnection Flag
16	_01_CH6_IDD	BIT	U01.10.6	Analog Input Module: CH6 Input Disconnection Flag
17	_01_CH7_IDD	BIT	U01.10.7	Analog Input Module: CH7 Input Disconnection Flag
18	_01_ERR_CLR	BIT	U01.11.2	Analog Input Module: Error Clear Request
19	_01_CH0_DATA	WORD	U01.02	Analog Input Module: CH0 Output
20	_01_CH1_DATA	WORD	U01.03	Analog Input Module: CH1 Output
21	_01_CH2_DATA	WORD	U01.04	Analog Input Module: CH2 Output
22	_01_CH3_DATA	WORD	U01.05	Analog Input Module: CH3 Output
23	_01_CH4_DATA	WORD	U01.06	Analog Input Module: CH4 Output
24	_01_CH5_DATA	WORD	U01.07	Analog Input Module: CH5 Output
25	_01_CH6_DATA	WORD	U01.08	Analog Input Module: CH6 Output
26	_01_CH7_DATA	WORD	U01.09	Analog Input Module: CH7 Output

## 4.6.2 Save variables

- 1) The contents of 'View Variable' can be saved as a text file.
- 2) Select [Edit] -> [Export to File].
- 3) The contents of 'View variable' are saved as a text file.

# Chapter 4 Operation Procedures and Monitoring

## 4.6.3 View variables

1) The example program of XG5000 is as shown in below.

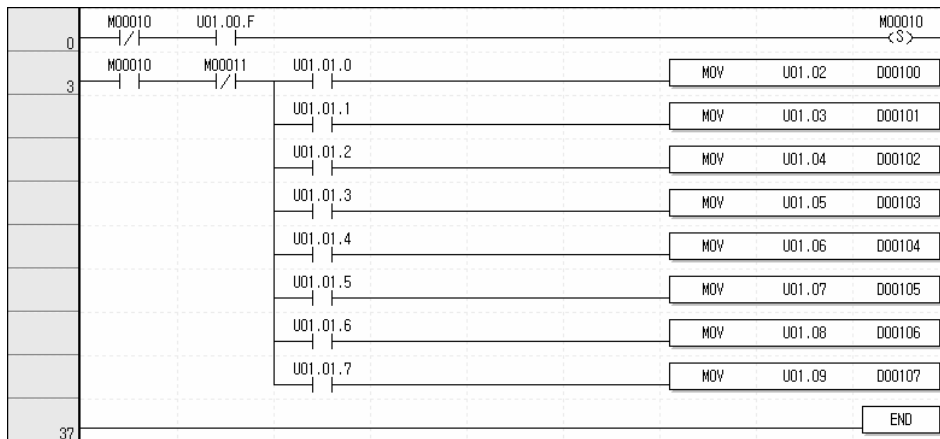

2) Select [View] -> [Variables]. The devices are changed into variables.

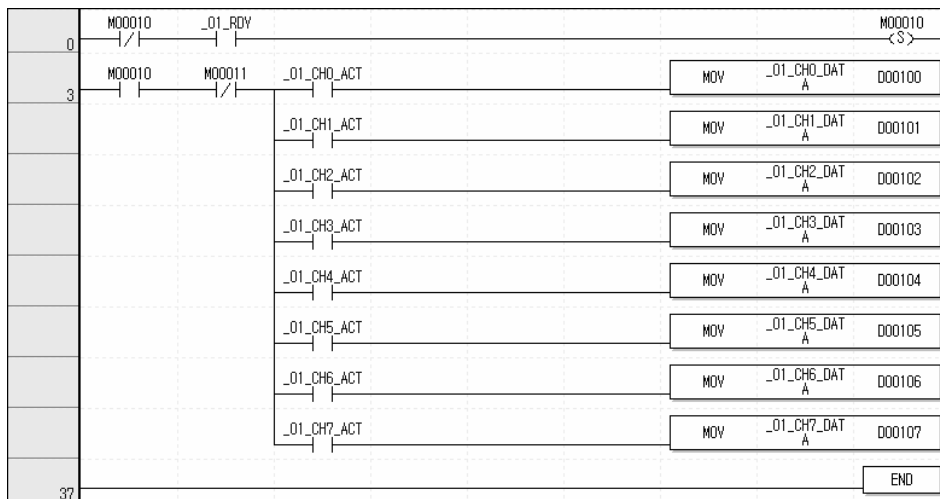

## Chapter 4 Operation Procedures and Monitoring

4) Select [View] -> [Devices/Variables]. Devices and variables are both displayed.

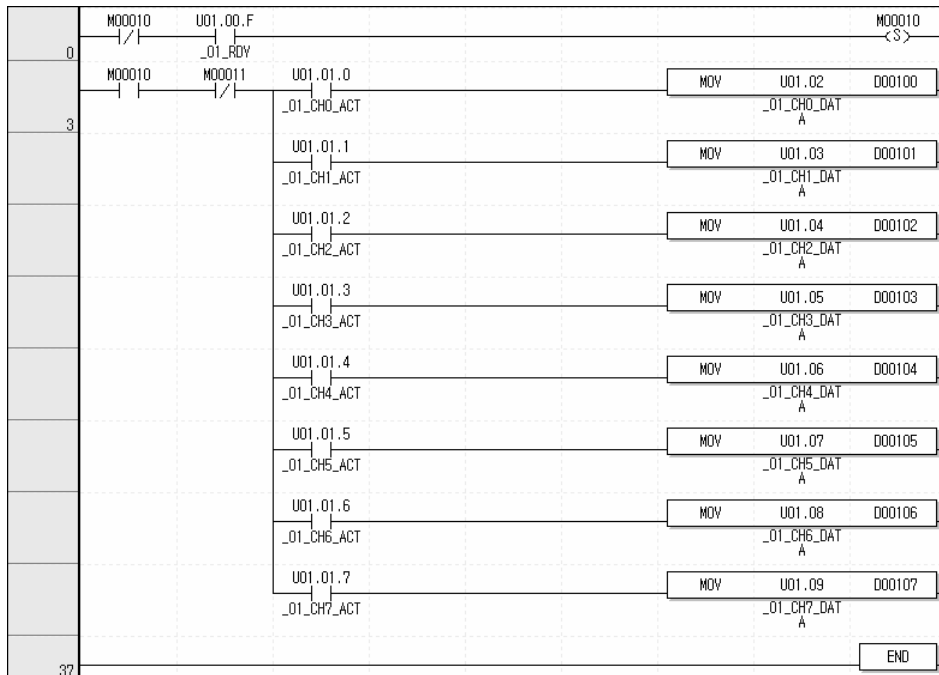

5) Select [View] -> [Device/Comments]. Devices and comments are both displayed.

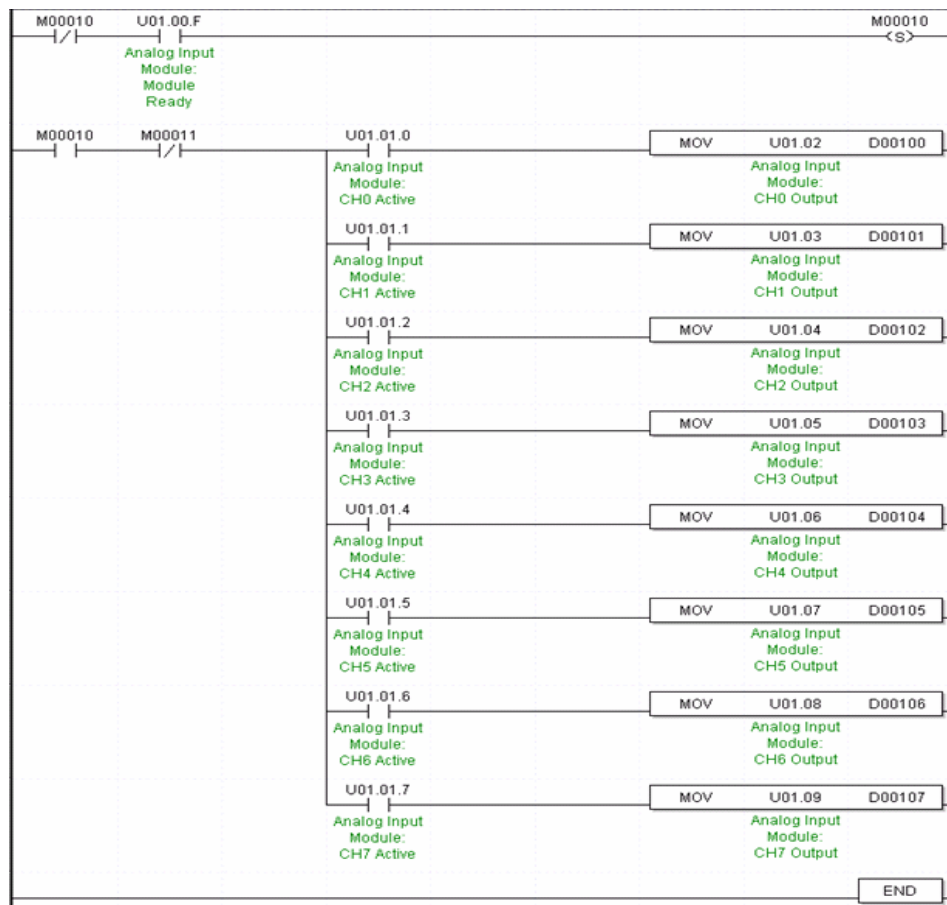

## Chapter 5 Configuration and Function of Internal Memory

A/D conversion module has the internal memory to transmit/receive data to/from PLC CPU.

### 5.1 Internal Memory Configuration

Configuration of internal memory is as described below.

#### 5.1.1 I/O area of A/D converted data

I/O area of A/D converted data is as displayed in Table 5.1.

[Table 5. 1] I/O area of A/D converted data

Device assigned	Details	R/W	Sign direction
UXY.00.0 UXY.00.F	Module ERROR flag Module READY flag	R	A/D → CPU
UXY.01.0 UXY.01.1 UXY.01.2 UXY.01.3 UXY.01.4 UXY.01.5 UXY.01.6 UXY.01.7	CH0 Run flag CH1 Run flag CH2 Run flag CH3 Run flag CH4 Run flag CH5 Run flag CH6 Run flag CH7 Run flag	R	A/D → CPU
UXY.02	CH0 digital output value	R	A/D → CPU
UXY.03	CH1 digital output value	R	
UXY.04	CH2 digital output value	R	
UXY.05	CH3 digital output value	R	
UXY.06	CH4 digital output value	R	
UXY.07	CH5 digital output value	R	
UXY.08	CH6 digital output value	R	
UXY.09	CH7 digital output value	R	
UXY.10.0 UXY.10.1 UXY.10.2 UXY.10.3 UXY.10.4 UXY.10.5 UXY.10.6 UXY.10.7	Flag to detect CH0 disconnection (1 ~ 5 V or 4 ~ 20 mA) Flag to detect CH1 disconnection (1 ~ 5 V or 4 ~ 20 mA) Flag to detect CH2 disconnection (1 ~ 5 V or 4 ~ 20 mA) Flag to detect CH3 disconnection (1 ~ 5 V or 4 ~ 20 mA) Flag to detect CH4 disconnection (1 ~ 5 V or 4 ~ 20 mA) Flag to detect CH5 disconnection (1 ~ 5 V or 4 ~ 20 mA) Flag to detect CH6 disconnection (1 ~ 5 V or 4 ~ 20 mA) Flag to detect CH7 disconnection (1 ~ 5 V or 4 ~ 20 mA)	R	A/D → CPU
UXY.11.0	Flag to request error clear	W	CPU → A/D

- 1) In the device assigned, X stands for the Base No. and Y for the Slot No. on which module is installed.
- 2) In order to read 'CH1 digital output value' of A/D conversion module installed on Base No.0, Slot No.4, it shall be displayed as U04.03.

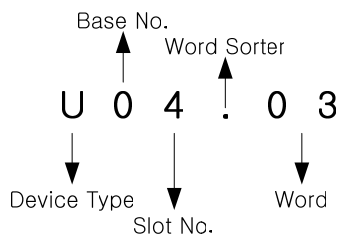

- 3) In order to read 'Flag to detect CH4 disconnection' of A/D conversion module installed on Base No.0, Slot No.5, it shall be displayed as U05.10.4.

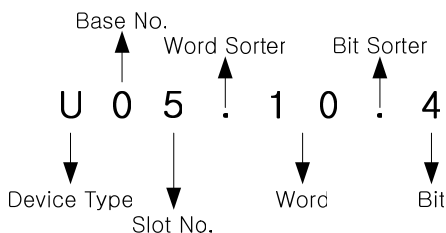

5.1.2 Operation parameters setting area

Setting area of A/D conversion module's Run parameters is as described in Table 5.2.

[Table 5. 2] Setting area of Run parameters

Memory address		Details	R/W	Remarks
Hex	Dec			
0 <sub>H</sub>	0	Channel enable/disable setting	R/W	PUT
1 <sub>H</sub>	1	Setting ranges of input voltage/current	R/W	PUT
2 <sub>H</sub>	2	Output data format setting	R/W	PUT
3 <sub>H</sub>	3	Filter processing enable/disable setting	R/W	PUT
4 <sub>H</sub>	4	CH0 filter constant	R/W	PUT
5 <sub>H</sub>	5	CH1 filter constant		
6 <sub>H</sub>	6	CH2 filter constant		
7 <sub>H</sub>	7	CH3 filter constant		
8 <sub>H</sub>	8	CH4 filter constant		
9 <sub>H</sub>	9	CH5 filter constant		
A <sub>H</sub>	10	CH6 filter constant		
B <sub>H</sub>	11	CH7 filter constant		
C <sub>H</sub>	12	Average processing enable/disable setting	R/W	PUT
D <sub>H</sub>	13	Average processing method setting	R/W	
E <sub>H</sub>	14	CH0 average value	R/W	
F <sub>H</sub>	15	CH1 average value		
10 <sub>H</sub>	16	CH2 average value		
11 <sub>H</sub>	17	CH3 average value		
12 <sub>H</sub>	18	CH4 average value		
13 <sub>H</sub>	19	CH5 average value		
14 <sub>H</sub>	20	CH6 average value		
15 <sub>H</sub>	21	CH7 average value		
16 <sub>H</sub>	22	Error code	R/W	GET

※ R/W is to denote Read/Write if available from PLC program.

**5.2 A/D Converted Data I/O Area**

**5.2.1 Module READY/ERROR flag (UXY.00, X: Base No., Y: Slot No.)**

- 1) **UXY.00.F**: It will be ON when PLC CPU is powered or reset with A/D conversion ready to process A/D conversion.
- 2) **UXY.00.0**: It is a flag to display the error status of A/D conversion module.

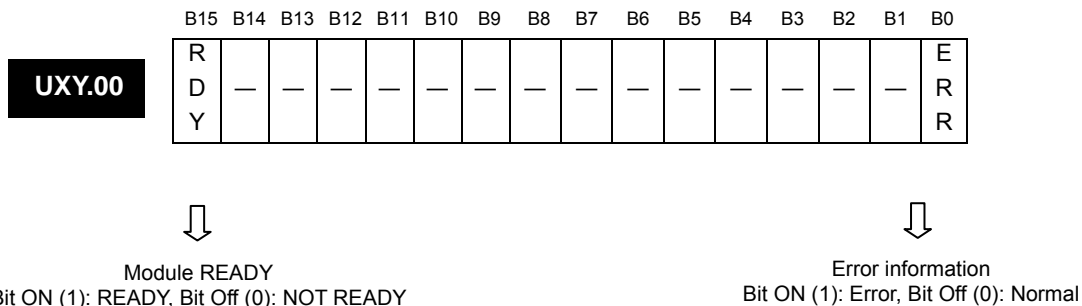

**5.2.2 Run channel flag (UXY.01, X: Base No., Y: Slot No.)**

The area where Run information of respective channels is saved.

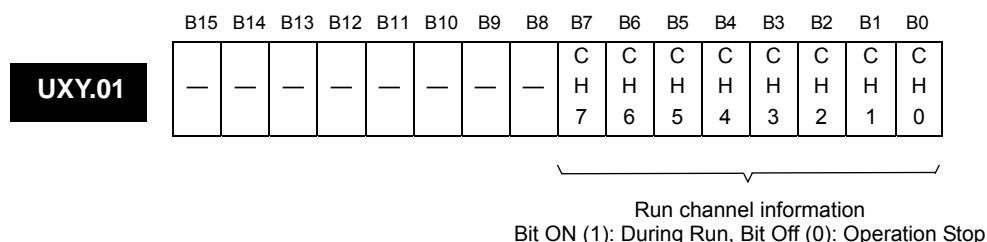

**5.2.3 Digital output value (UXY.02 ~ UXY.09, X: Base No., Y: Slot No.)**

- 1) A/D converted-digital output value will be output to buffer memory addresses 2 ~ 9 (UXY.02 ~ UXY.09) for respective channels.
- 2) Digital output value will be saved in 16-bit binary.

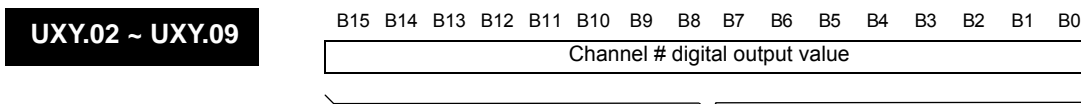

Address	Details
Address No.2	CH0 digital output value
Address No.3	CH1 digital output value
Address No.4	CH2 digital output value
Address No.5	CH3 digital output value
Address No.6	CH4 digital output value
Address No.7	CH5 digital output value
Address No.8	CH6 digital output value
Address No.9	CH7 digital output value

**5.2.4 Flag to detect disconnection (UXY.10.Z, X: Base No., Y: Slot No., Z: Channel No.)**

- 1) Detection sign of disconnection for respective input channels is saved in UXY.10.
- 2) Each bit will be set to 1 if an assigned channel is detected as disconnected, and it will be back to 0 if connected back. In addition, each bit can be used to detect the disconnection in the user program together with execution conditions.

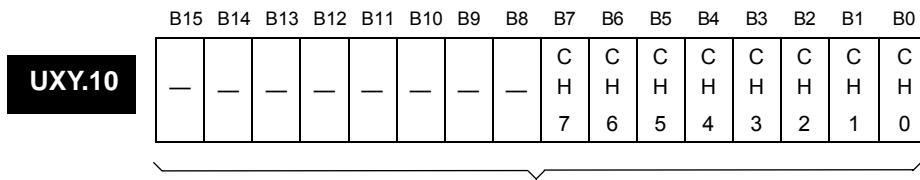

BIT	Description
0	Normal
1	disconnection

**5.2.5 Flag to request error clear (UXY.11.0, X: Base No., Y: Slot No.)**

- 1) If a parameters setting error occurs, address No.22's error code will not be automatically erased even if parameters are changed correctly. At this time, turn the 'error clear request' bit ON to delete address No.22's error code and the error displayed in XG5000's [System Monitoring]. In addition, RUN LED which blinks will be back to On status.
- 2) The 'flag to request error clear' shall be used surely together with UXY.00.0 attached thereon for guaranteed Normal operation. Its application shall be as shown below in Fig. 5.1.

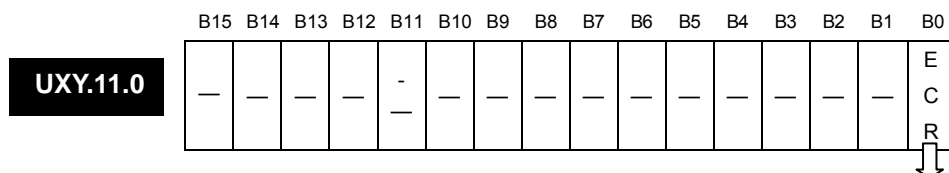

Flag to request error clear (UXY.11.0)  
Bit ON (1): Error clear request, Bit Off (0): Error clear standing-by

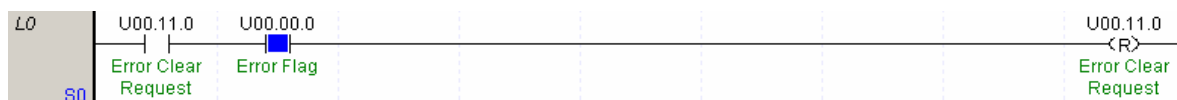

[Fig. 5. 1] How to use the flag

### 5.3 Operation Parameters Setting Area

- ▶ 1 word is assigned for each address in the internal memory, which can be displayed in 16 bits.
- ▶ If each bit of 16 bits configuring the address is On, let it set to “1”, and if it is Off, let it set to “0” so to realize the respective functions.

#### 5.3.1 How to specify the channel to use (address No.0)

- 1) Allowed/Prohibited A/D conversion can be set for respective channels.
- 2) Set the unused channel Prohibited from converted so to reduce the conversion cycle for respective channels.
- 3) If the channel to use is not specified, all the channels will be set to Prohibited.
- 4) Allowed/Prohibited A/D conversion is as specified below.

	B15	B14	B13	B12	B11	B10	B9	B8	B7	B6	B5	B4	B3	B2	B1	B0
<b>Address “0”</b>	—	—	—	—	—	—	—	—	C	C	C	C	C	C	C	C
	—	—	—	—	—	—	—	—	H	H	H	H	H	H	H	H
										7	6	5	4	3	2	1

BIT	Description
0	Disable
1	Enable

- 5) The value specified in B8 ~ B15 will be disregarded.

#### 5.3.2 How to specify the range of input voltage/current (address No.1)

- 1) The range of analog input voltage/current can be specified for respective channels.
- 2) If the analog input range is not specified, the range of all the channels will be set to 1 ~ 5 V (4 ~ 20 mA).
- 3) Setting range of analog input voltage/current is as specified below.

(1) XGF-AV8A

	B15	B14	B13	B12	B11	B10	B9	B8	B7	B6	B5	B4	B3	B2	B1	B0
<b>Address “1”</b>	C	C	C	C	C	C	C	C	C	C	C	C	C	C	C	C
	H	H	H	H	H	H	H	H	H	H	H	H	H	H	H	H

BIT	Description
00	1 V ~ 5 V
01	0 V ~ 5 V
10	0 V ~ 10 V
11	-10 V ~ 10 V

(2) XGF-AC8A

<b>Address "1"</b>	B15	B14	B13	B12	B11	B10	B9	B8	B7	B6	B5	B4	B3	B2	B1	B0
	C	C	C	C	C	C	C	C	C	C	C	C	C	C	C	C
	H	H	H	H	H	H	H	H	H	H	H	H	H	H	H	H
	7	6	5	4	3	2	1	0								

BIT	Description
00	4 mA ~ 20 mA
01	0 mA ~ 20 mA

**5.3.3 How to specify the range of output data (address No.2)**

- 1) The range of digital output data for analog input can be specified for respective channels.
- 2) If the output data range is not specified, the range of all the channels will be set to 0 ~ 16000.
- 3) Setting range of digital output data range is as specified below.

<b>Address "2"</b>	B15	B14	B13	B12	B11	B10	B9	B8	B7	B6	B5	B4	B3	B2	B1	B0
	C	C	C	C	C	C	C	C	C	C	C	C	C	C	C	C
	H	H	H	H	H	H	H	H	H	H	H	H	H	H	H	H
	7	6	5	4	3	2	1	0								

BIT	Description
00	0 ~ 16000
01	-8000 ~ 8000
10	Precise Value
11	0 ~ 10000

Precise value has the following digital output ranges for the analog input range.

(1) XGF-AV8A

Analog input Digital output	-10 ~ 10V	0 ~ 10V	0 ~ 5V	1 ~ 5V
Precise Value	-10000 ~ 10000	0 ~ 10000	0 ~ 5000	1000 ~ 5000

(2) XGF-AC8A

Analog input Digital output	4 ~ 20 mA	0 ~ 20 mA
Precise Value	4000 ~ 20000	0 ~ 20000

### 5.3.4 How to specify filter process (address No.3)

- 1) Allowed/Prohibited filter process can be specified for respective channels.
- 2) If the filter process is not specified, all the channels will be sampled.
- 3) Setting of the filter process is as specified below.

<b>Address "3"</b>	B15	B14	B13	B12	B11	B10	B9	B8	B7	B6	B5	B4	B3	B2	B1	B0
	—	—	—	—	—	—	—	—	C	C	C	C	C	C	C	C
									H	H	H	H	H	H	H	H
									7	6	5	4	3	2	1	0

BIT	Description
0	Disable
1	Enable

### 5.3.5 How to specify filter constant (address No.4 ~ 11)

- 1) Default of the filter constant is 1.
- 2) Setting range of the filter constant is 1 ~ 99.
- 3) If other value exceeding the setting range is specified, error code 50# will be displayed on display address (22) of the error code. At this time, A/D converted value keeps the previous data. (# of the error code stands for the channel with error found)
- 4) If the filter constant is not specified, the filter constant will be set to '1'.
- 5) Setting of the filter constant is as specified below.

<b>Address "4 ~ 11"</b>	B15	B14	B13	B12	B11	B10	B9	B8	B7	B6	B5	B4	B3	B2	B1	B0
	—	—	—	—	—	—	—	—	Channel# filter value							

Setting range of filter constant is 1 ~ 99

Address	Details
Address No.4	CH0 filter value
Address No.5	CH1 filter value
Address No.6	CH2 filter value
Address No.7	CH3 filter value
Address No.8	CH4 filter value
Address No.9	CH5 filter value
Address No.10	CH6 filter value
Address No.11	CH7 filter value

#### Notes

In order to make filter constant effective, the filter process shall be previously set to 'Allowed'.

**5.3.6 How to specify average process (address No.12)**

- 1) Allowed/Prohibited average process can be specified for respective channels.
- 2) If the average process is not specified, all the channels will be sampled.
- 3) Setting of the average process is as specified below.

<b>Address "12"</b>	B15	B14	B13	B12	B11	B10	B9	B8	B7	B6	B5	B4	B3	B2	B1	B0
	—	—	—	—	—	—	—	—	C H 7	C H 6	C H 5	C H 4	C H 3	C H 2	C H 1	C H 0

BIT	Description
0	Disable
1	Enable

**5.3.7 How to specify average processing method (address No.13)**

- 1) This area is used to specify average processing method, where 'count average' and 'time average' are available.
- 2) If any time/count average process is not specified, all the channels will be set to count average process.

<b>Address "13"</b>	B15	B14	B13	B12	B11	B10	B9	B8	B7	B6	B5	B4	B3	B2	B1	B0
	—	—	—	—	—	—	—	—	C H 7	C H 6	C H 5	C H 4	C H 3	C H 2	C H 1	C H 0

BIT	Description
0	Count average
1	Time average

**Notes**

In order to specify time/count average process value, the average process shall be previously set to 'Allowed'.

**5.3.8 How to specify average value (address No.14 ~ 21)**

- 1) Setting range of time/count average's constant value is as specified below.
  - (1) Setting range of time average: 4 ~ 16000 (ms)
  - (2) Setting range of count average: 2 ~ 64000 (times)
- 2) In case other value exceeding the setting range is specified, (1) Error No. 60X will be displayed if time average range exceeded, and (2) Error No. 70X will be displayed if count average range exceeded on the display address of the respective error codes. At this time, the default of average process will be applied and calculated.
- 3) If the process value of time/count average is not specified, the default will be applied and calculated. (Time average: 4, Count average: 2)
- 4) The process value of time/count average is as specified below.

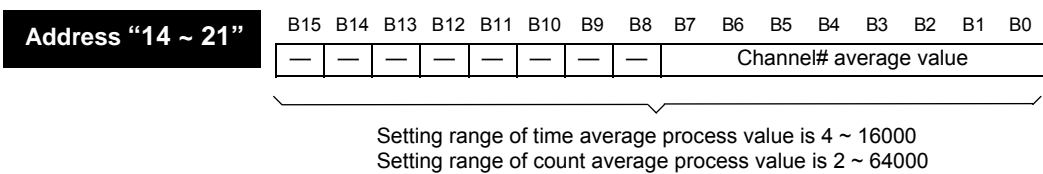

Address	Details
14	CH0 average value
15	CH1 average value
16	CH2 average value
17	CH3 average value
18	CH4 average value
19	CH5 average value
20	CH6 average value
21	CH7 average value

**Notes**

In order to specify the process value of time/count average, the average process shall be previously set to 'Allowed'. In addition, an average processing method shall be selected between time average and count average as desired.

5.3.9 Error code (address No.22)

- 1) Error codes detected from A/D conversion module will be saved.
- 2) Error types and details are as specified below.

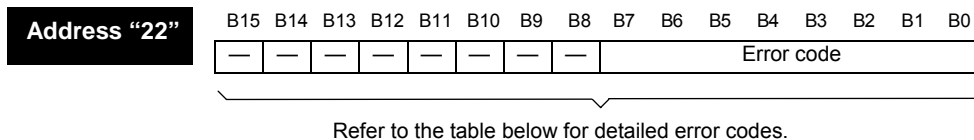

Refer to the table below for detailed error codes.

Error Code (Dec)	Error Details	Remarks
0	Normal Run	RUN LED On
20	Module error (A/D Conversion Error)	RUN LED flickers every 0.2 sec.
40#	Offset value with the range of 1 ~ 5 V (4 ~ 20 mA) is set greater than or equal to Gain value.	RUN LED flickers every 11 sec.
41#	Offset value with the range of 0 ~ 5 V (0 ~ 20 mA) is set greater than or equal to Gain value.	
42#	Offset value with the range of 0 ~ 10 V is set greater than or equal to Gain value.	
43#	Offset value with the range of -10 ~ 10 V is set greater than or equal to Gain value.	
50#	Filter constant setting range exceeded	
60#	Time average setting range exceeded	
70#	Count average setting range exceeded	
80#	Analog input range setting error	Applied to XGF-AC8A

- ※ # of the error code stands for the channel with error found.
- ※ Refer to 7.1 for more details on error codes.

- 3) If 2 or more errors occur, the module will not save other error codes than the first error code found.
- 4) If an error found is corrected, use the 'flag to request error clear' (refer to 5.2.5), or let power OFF → ON in order to stop LED blinking and to delete the error code.

# Chapter 6 Programming

## 6.1 Read/Write of Operation Parameters Setting Area

Configuration of the internal memory is described as below.

### 6.1.1 Read of operation parameters setting area (GET, GETP instruction)

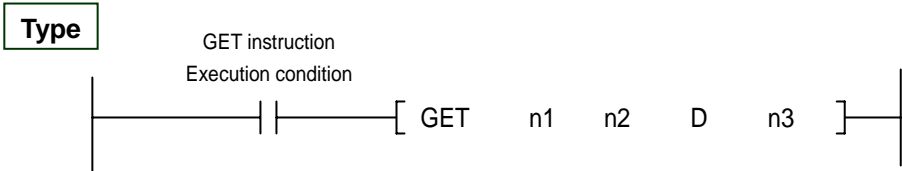

Type	Description	Area available
n1	Slot No. the special module is installed on	Integer
n2	Start address of setting area of special module's Run parameters to read data.	Integer
D	Device's start address with saved data to read	M, P, K, L, T, C, D, #D
n3	Number of words data to read	Integer

< Difference between GET instruction and GETP instruction >

GET : always executed with execution condition On ( )  
 GETP : executed with execution condition of operation start ( )

**Ex.** If A/D conversion module is installed on Base No.0 and Slot No.3, and internal memory addresses No.0 & 1's data in A/D conversion module is read to D0 and D1 of CPU module,

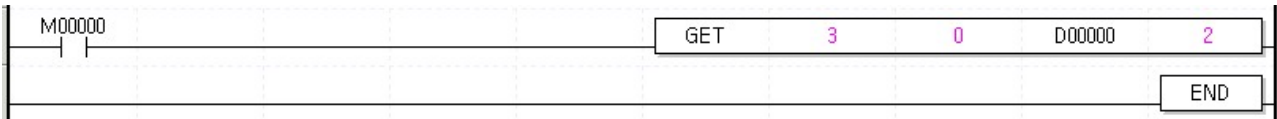
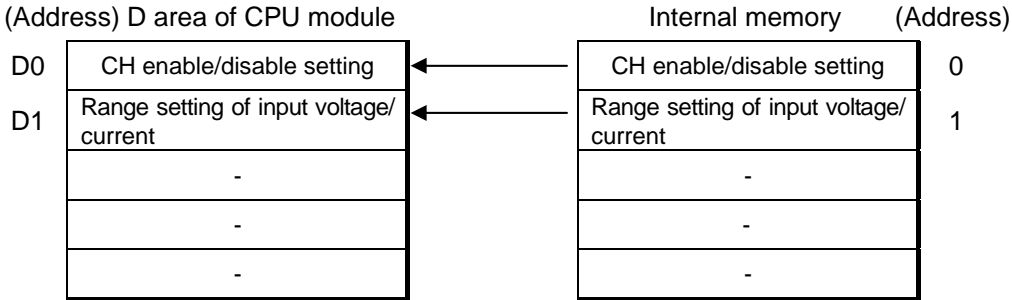

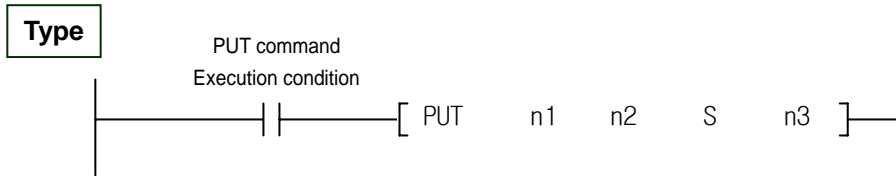

## 6.1.2 Write of operation parameters setting area (PUT, PUTP instruction)



Type	Description	Area available
n1	Slot No. the special module is installed on	Integer
n2	Start address of special module's internal memory to write data.	Integer
S	Device's start address or integer with saved data to write.	M,P,K,L,T,C,D,#D,integer
n3	Number of words data to write	Integer

< Difference between PUT instruction and PUTP instruction >

PUT : always executed with execution condition On (  )  
 PUTP : executed with execution condition of operation start (  )

**Ex.** If A/D conversion module is installed on Base No.0 and Slot No.6, and CPU module's data of D10~D13 is written on internal memory addresses 12~15 of A/D conversion module,

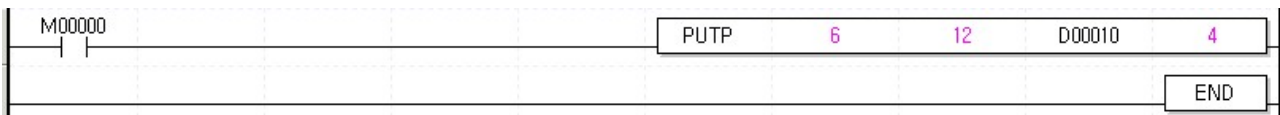
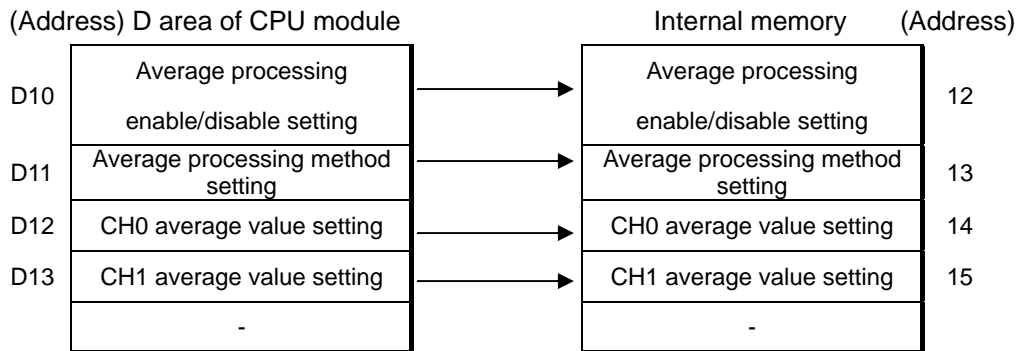

## 6.2 Basic Program

- How to specify Run condition details of A/D conversion module's internal memory will be described.
- A/D conversion module is as installed on Slot 2.
- I/O assigned points of A/D conversion module is 16 points (changeable).
- Initial value specified will be saved on the internal memory of A/D module through one time of input under the initial setting condition.

### 6.2.1 XGF-AV8A

- 1) Program example using [I/O parameters] setting

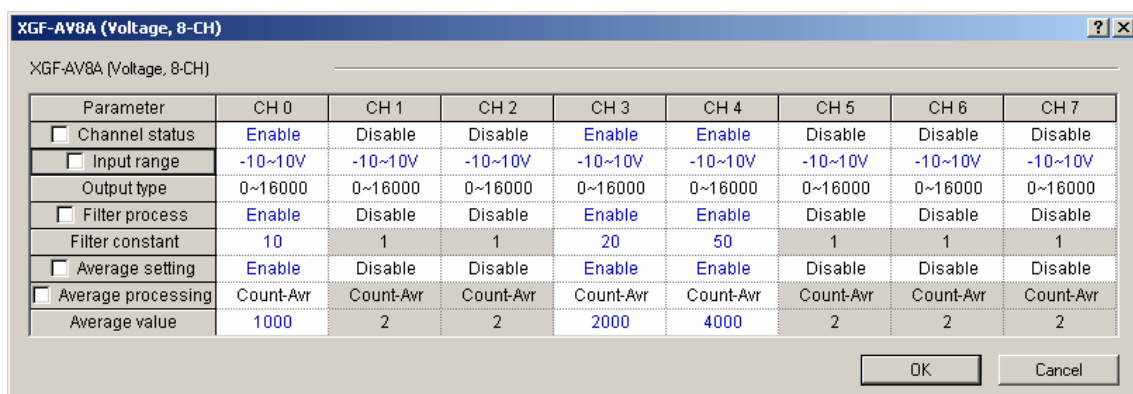
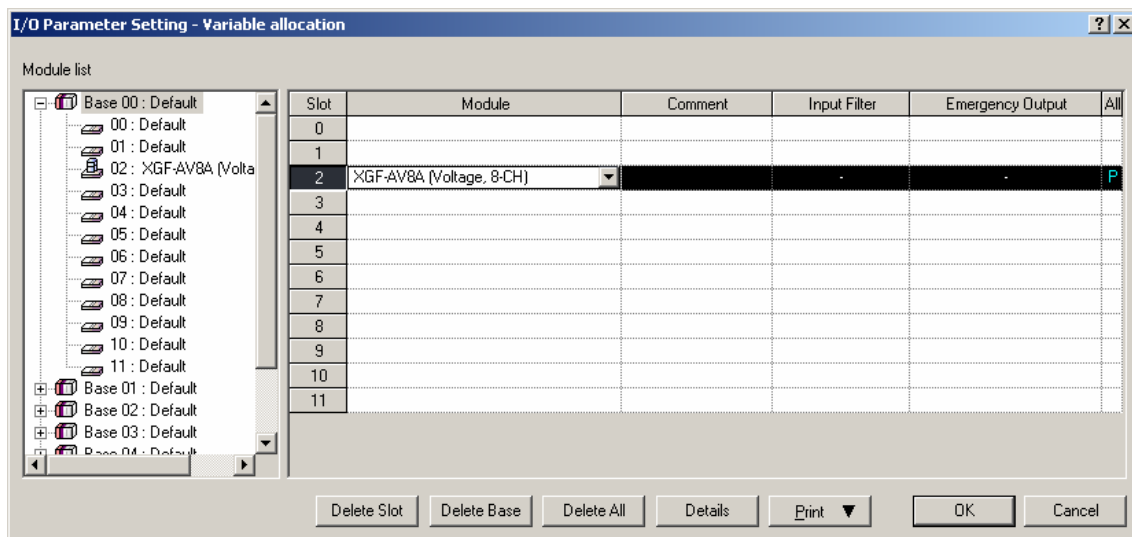

# Chapter 6 Programming

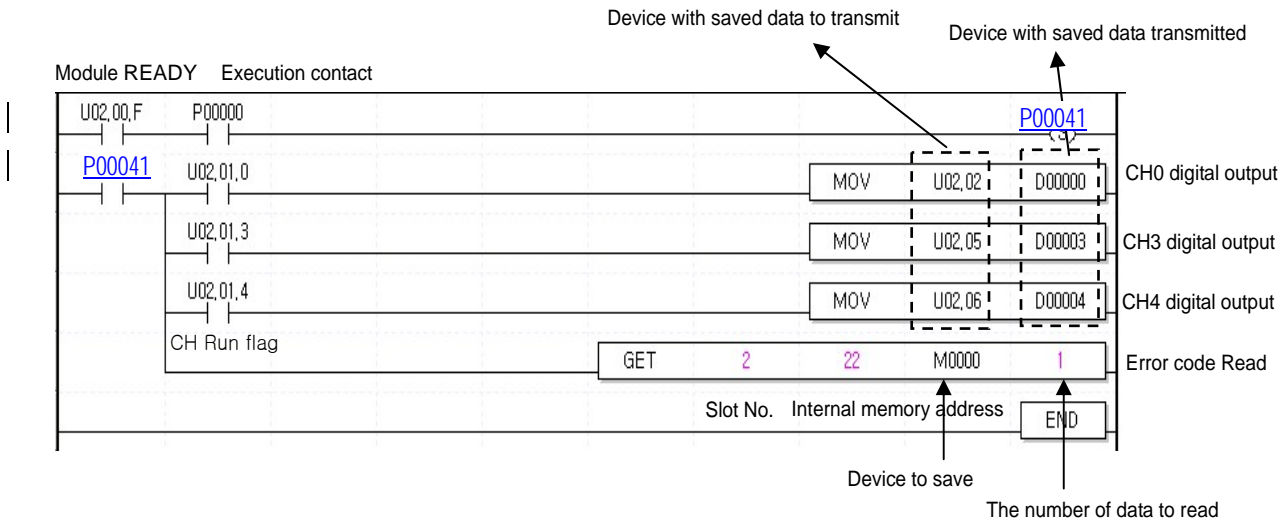

## 2) Program example using PUT/GET instruction

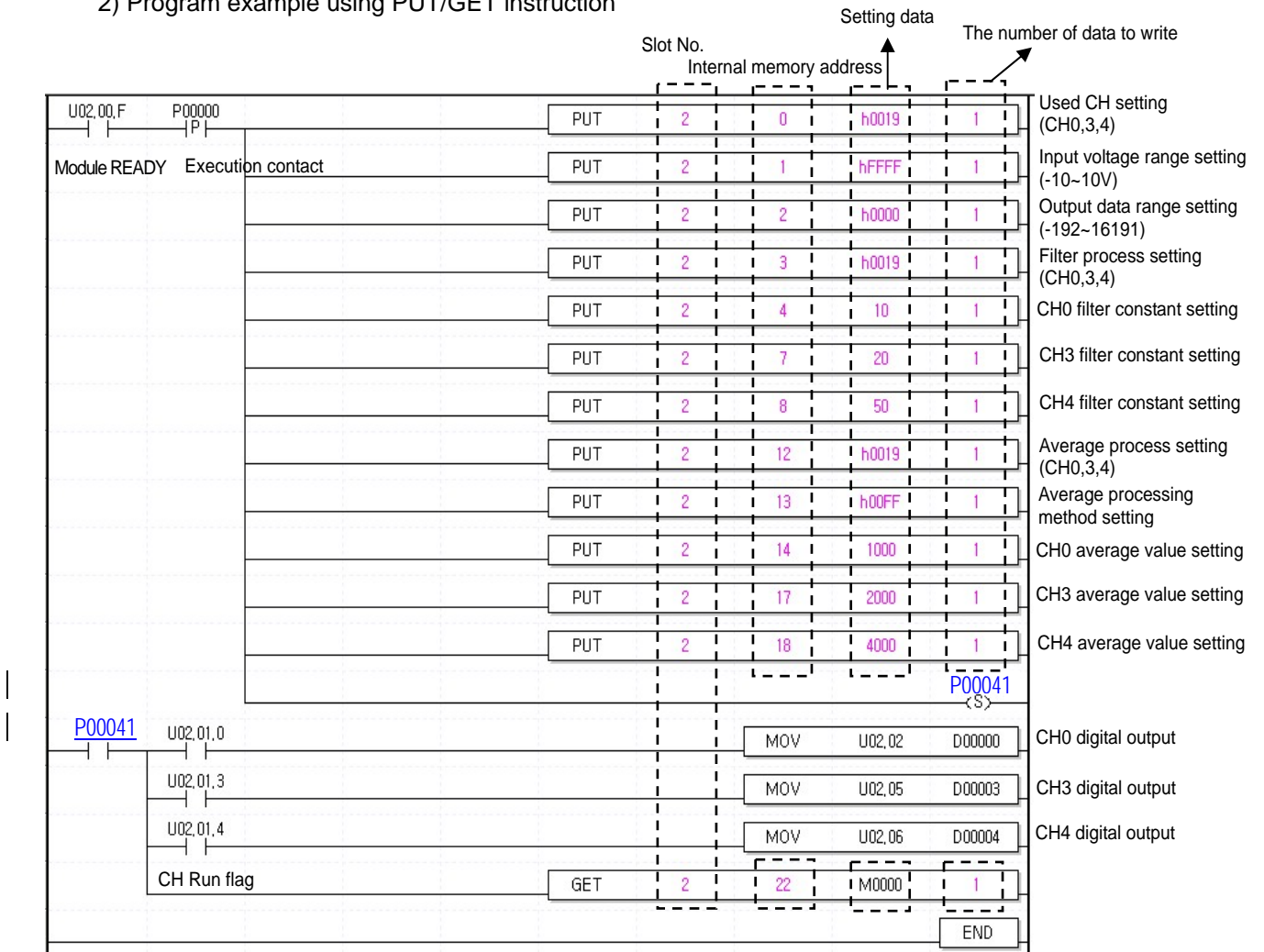

### 6.2.2 XGF-AC8A

1) Program example using [I/O parameters] setting

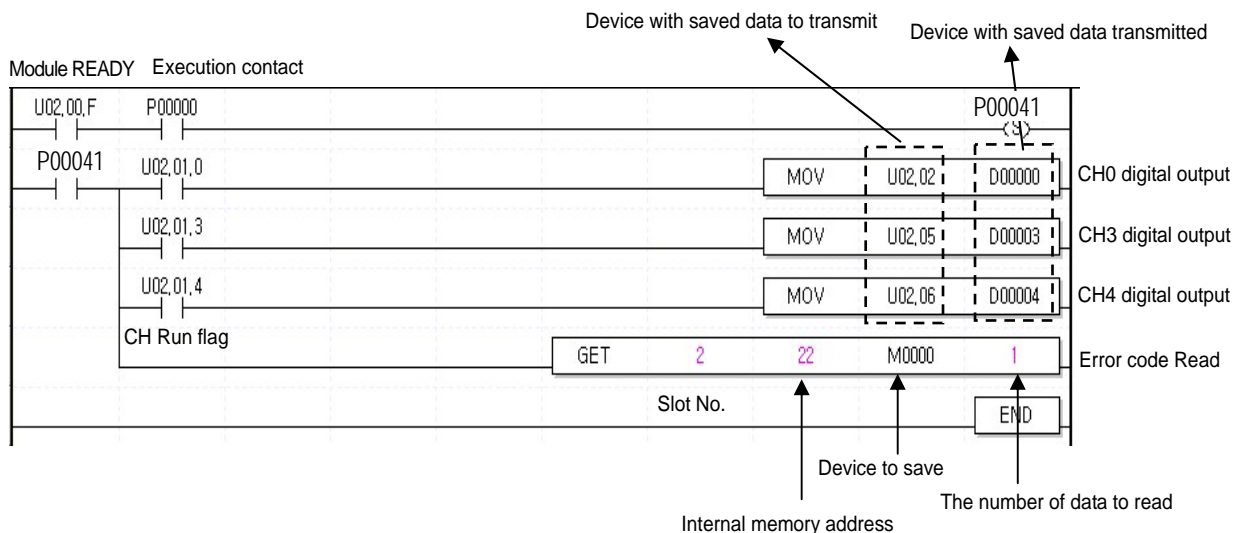
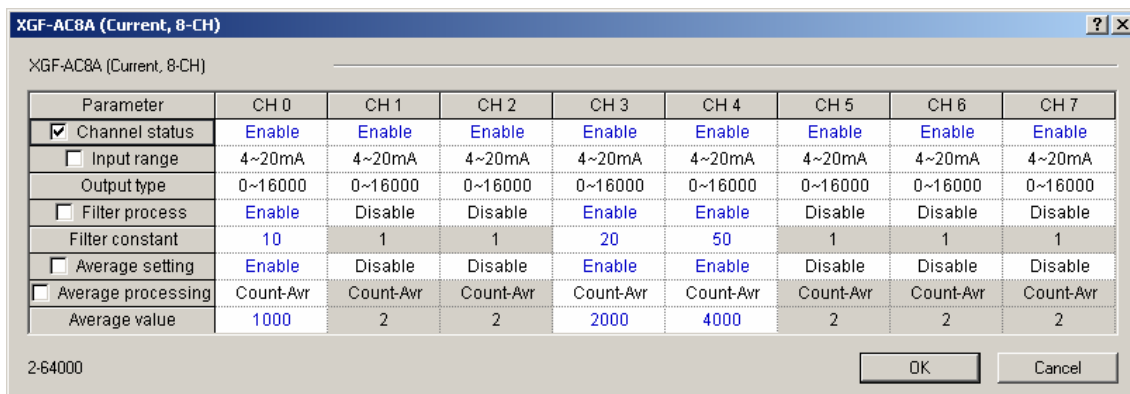
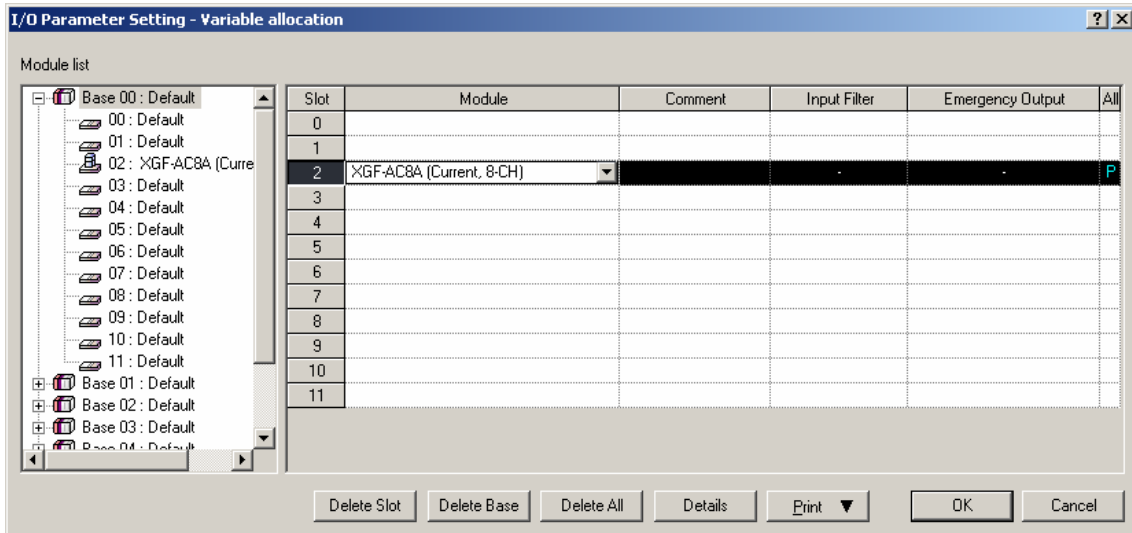

# Chapter 6 Programming

## 2) Program example using PUT/GET instruction

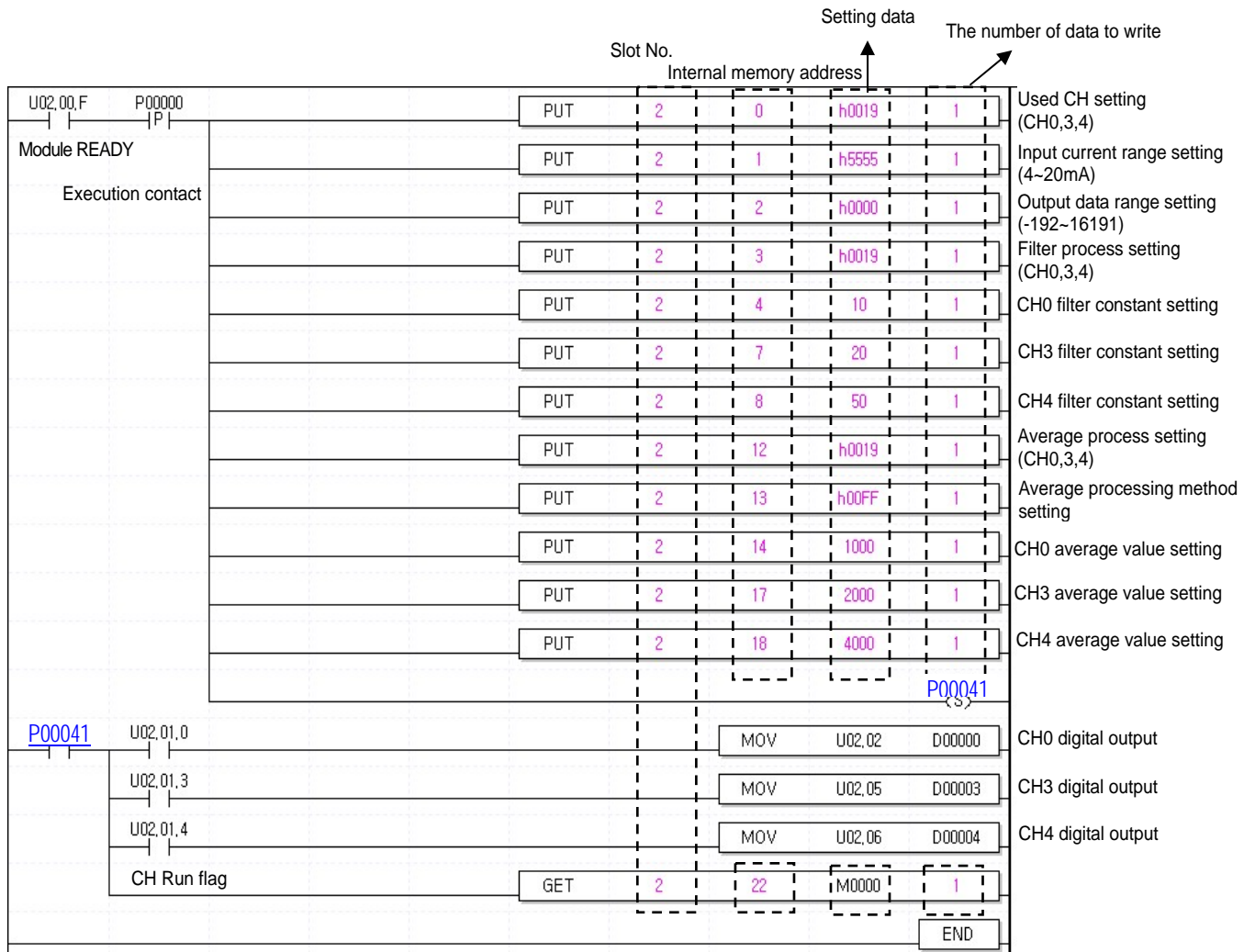

## 6.3 Application Program

### 6.3.1 Program to sort A/D converted value in size (I/O slot fixed-points assigned: based on 64)

#### 1) System configuration

XGP- ACF2	XGK- CPUS	XGI- D24A	XGF- AV8A	XGQ- RY2A	
--------------	--------------	--------------	--------------	--------------	--

#### 2) Details of initial setting

No.	Item	Details of initial setting	Internal memory address	Value to write on internal memory
1	Used CH	CH0, CH2, CH4	0	'h0015' or '21'
2	Input voltage range	-10 ~ 10 V	1	'hFFFF' or '65535'
3	Output data range	0 ~ 16000	2	'h0000' or '0'
4	Filter process	CH0	3	'h0001' or '1'
5	CH0 filter constant	50	4	'h0032' or '50'
6	Average process	CH2, CH4	12	'h0014' or '20'
6	Average processing method	Frequency average: CH2 Time average: CH4	13	'h0010' or '16'
7	Average value	Frequency average value: 100 (times)	16	'h0064' or '100'
		Time average value: 200 (ms)	18	'h00C8' or '200'

#### 3) Program description

- (1) If CH 0's digital value is less than 12000, Contact No.0 (P00080) of relay output module installed on Slot No.2 will be On
- (2) If CH 2's digital value is greater than 13600, Contact No.2 (P00082) of relay output module installed on Slot No.2 will be On.
- (3) If CH 4's digital value is greater than or equal to 12000 and less than or equal to 13600, Contact No.4 (P00084) of relay output module installed on Slot No.2 will be On.
- (4) If CH 4's digital value is equal to 13600, Contact No.5 (P00085) of relay output module installed on Slot No.2 will be On.

# Chapter 6 Programming

## 4) Program

### (1) Program example using [I/O parameters] setting

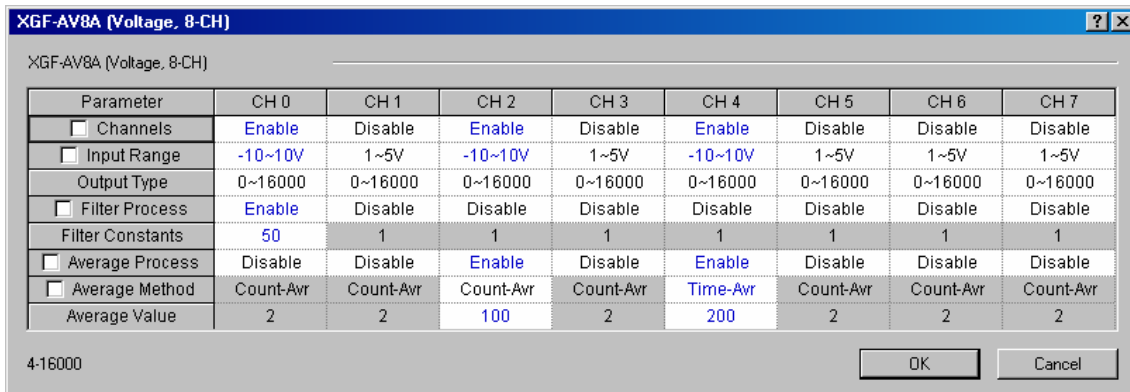
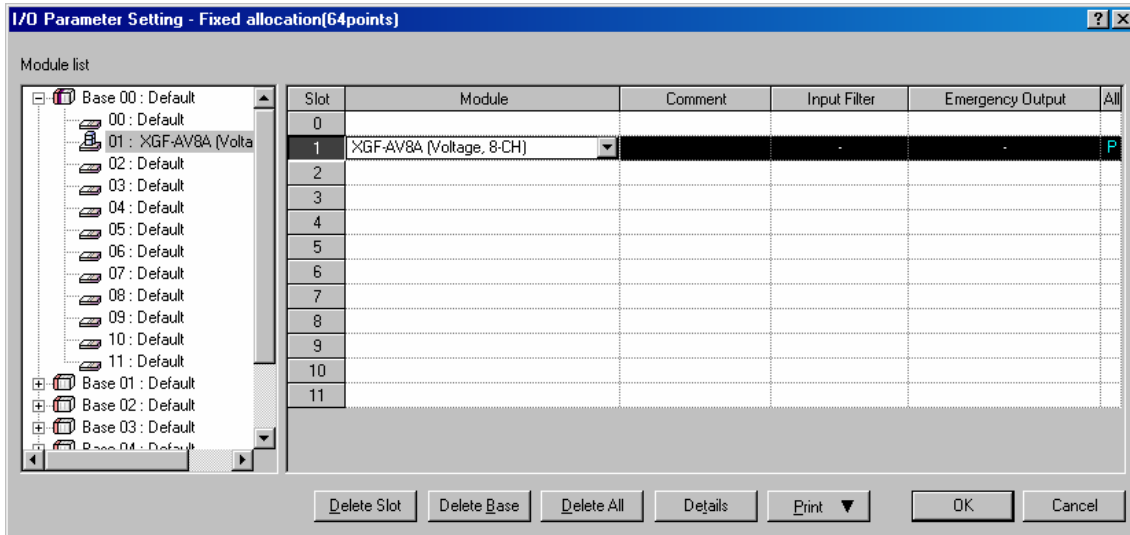

Module READY Execution contact

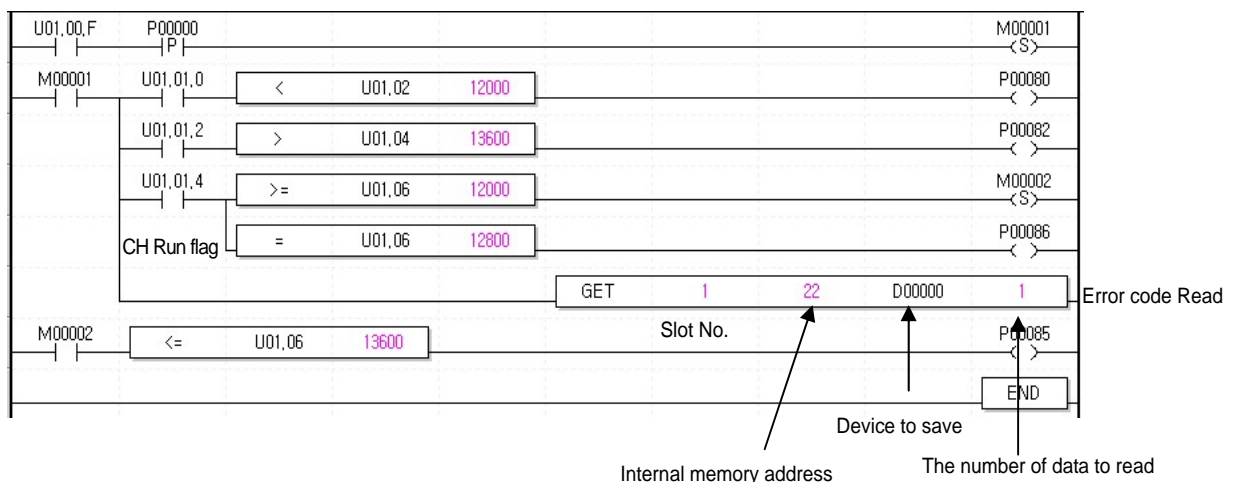

## (2) Program example using PUT/GET instruction

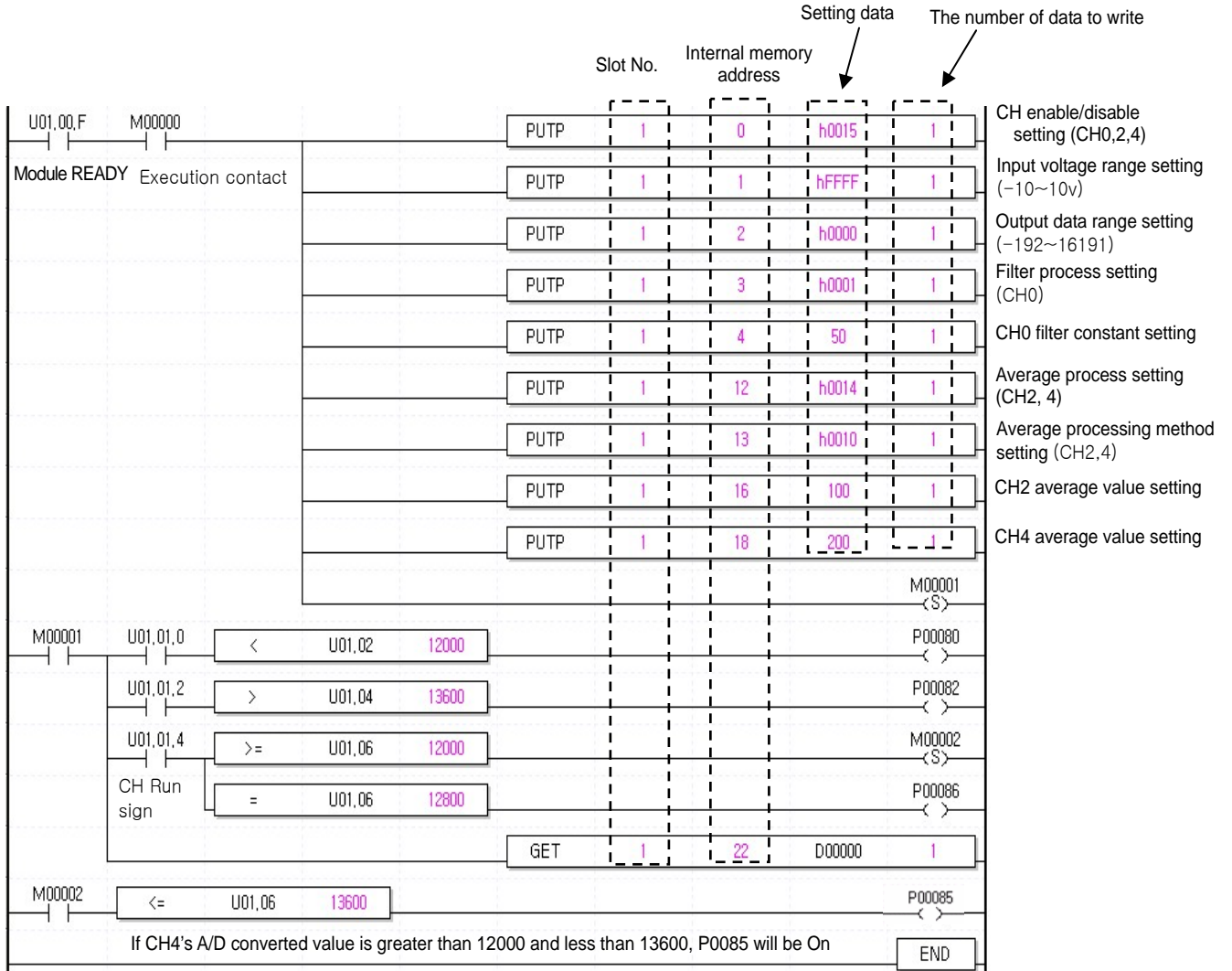

### 6.3.2 Program to output error codes of analog input module to BCD display

#### 1) System configuration

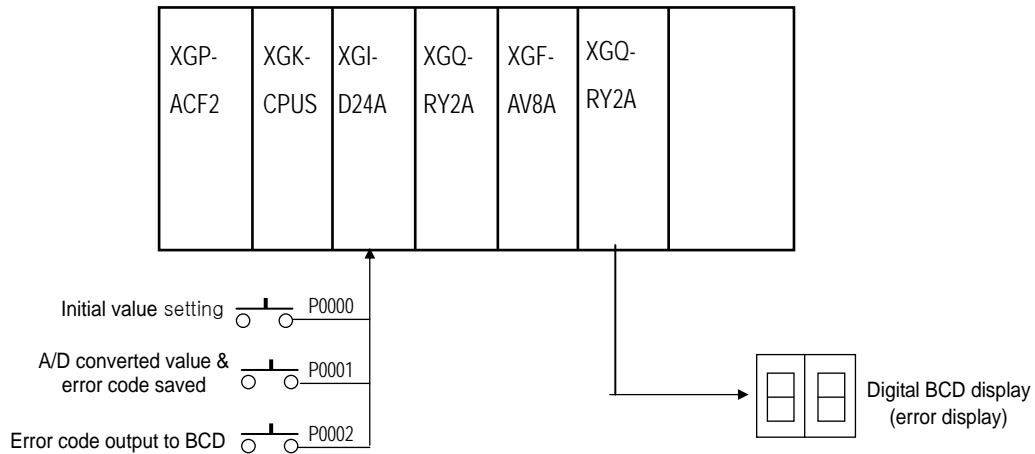

#### 2) Details of initial setting

- (1) Used CH: CH 0
- (2) Analog input current range: DC 4 ~ 20 mA
- (3) Time average process setting: 100 (ms)
- (4) Digital output data range: 0 ~ 16000

#### 3) Program description

- (1) If P00000 is On, A/D conversion will be initially specified.
- (2) If P00001 is On, A/D converted value and error code will be saved respectively on D00000 and D00001.
- (3) If P00002 is On, applicable error code will be output to digital BCD display. (P00040 ~ P0004F)

4) Program

(1) Program example through [I/O parameters] setting

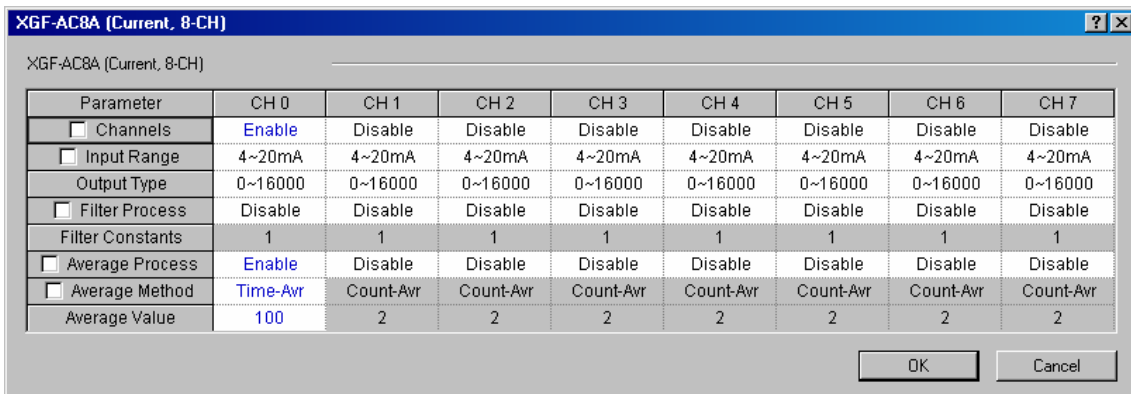
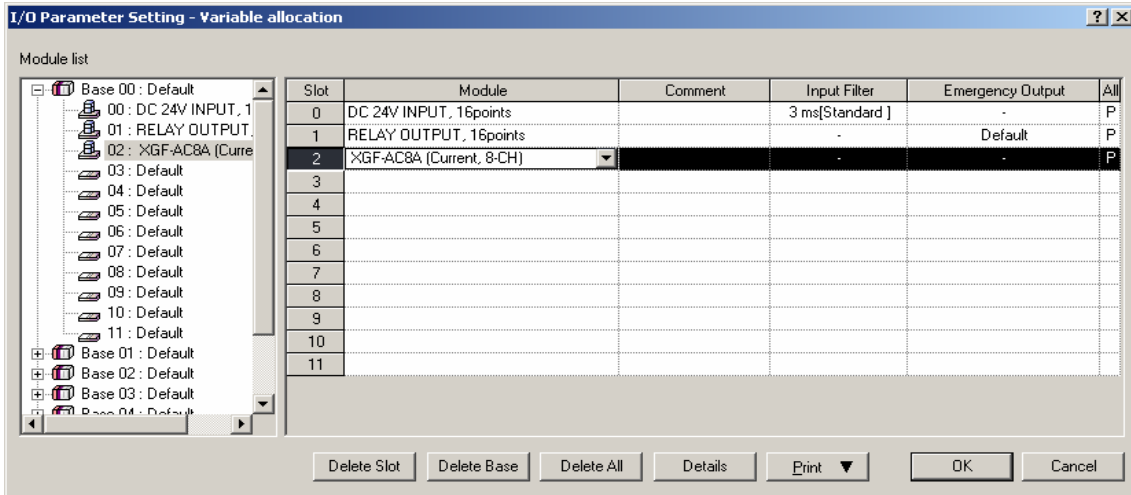

Module READY Execution contact

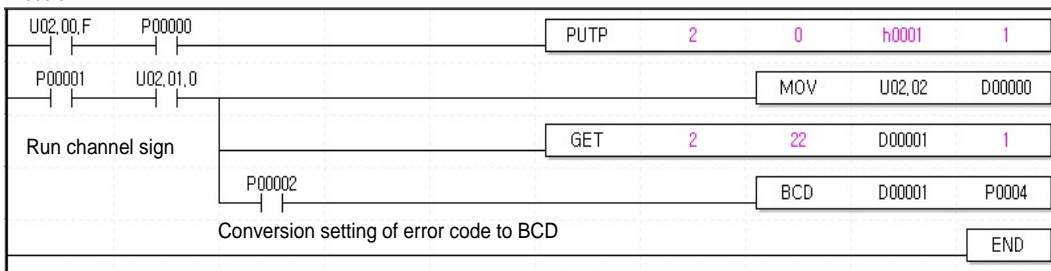

Channel enable/disable setting (CH0)  
 Save CH0's A/D converted value on D0  
 Save error code on D1  
 Convert D1 saved data to BCD to output to P040

# Chapter 6 Programming

## (2) Program example using PUT/GET instruction

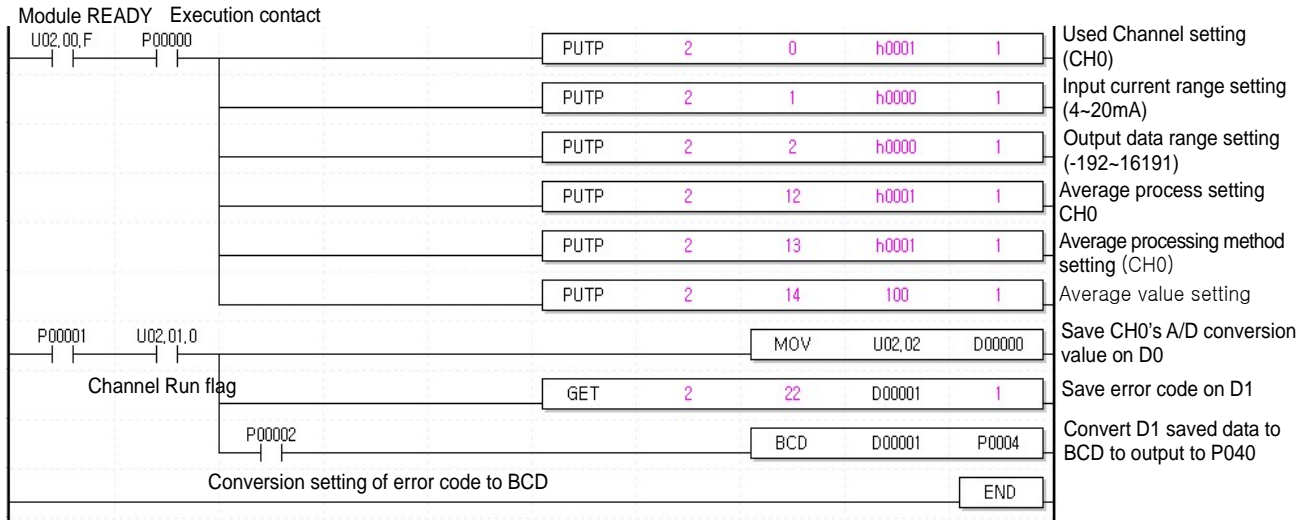

## Chapter 7 Troubleshooting

Details and diagnosis of errors which occur while analog input module is used will be described.

### 7.1 Error Codes

Errors which occur when A/D conversion module's RUN LED blinks are as described in Table 7.1.

[Table 7. 1] List of error codes

Error code (Dec)	Description	RUN LED status
10	Module error (ASIC Reset Error)	Flickers every 0.2 sec.
11	Module error (ASIC RAM or Register Error)	
20	Module error (A/D Conversion Error)	
30	Module error (EEPROM Error)	
40#	Module error (Offset value with the range of 1 ~ 5 V or 4 ~ 20 mA is set greater than or equal to Gain value.)	Flickers every 1 sec.
41#	Module error (Offset value with the range of 0 ~ 5 V or 0 ~ 20 mA is set greater than or equal to Gain value.)	
42#	Module error (Offset value with the range of 0 ~ 10 V is set greater than or equal to Gain value.)	
43#	Module error (Offset value with the range of -10 ~ 10 V is set greater than or equal to Gain value.)	
50#	Filter constant setting range exceeded	
60#	Time average setting range exceeded	
70#	Count average setting range exceeded	
80#	Analog input range setting error(only for XGF-AC8A)	

#### Notes

- (1) # of the error code stands for the channel with error found.
- (2) If 2 or more errors occur, the module will not save other error codes than the first error code found.
- (3) Use the flag to request error clear to delete the error code from the sequence program. (Refer to 5.2.5)

**7.2 Troubleshooting**

**7.2.1 RUN LED blinks**

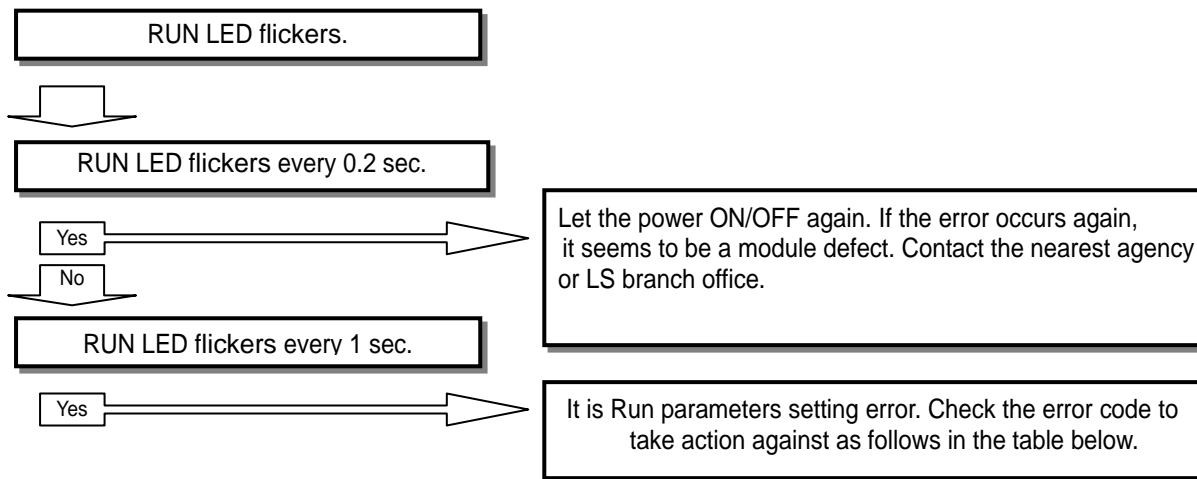

Error Code (Dec)	Error Details	Action
40#	Module Offset/Gain error	Let the power ON/OFF again. If the error occurs again, it seems to be a module defect. Contact the nearest agency or LS branch office.
41#		
42#		
43#		
50#	Filter constant setting range exceeded	Change filter constant setting value within 1 ~ 99.
60#	Time average setting range exceeded	Change time average setting value within 4 ~ 16000.
70#	Frequency average setting range exceeded	Change frequency average setting value within 2 ~ 64000.
80#	Analog input range error (Only XGF-AC8A)	Refer to the section 5.3.2 Parameter Setting Range Address 1 and then change the analog input range.

7.2.2 RUN LED is Off

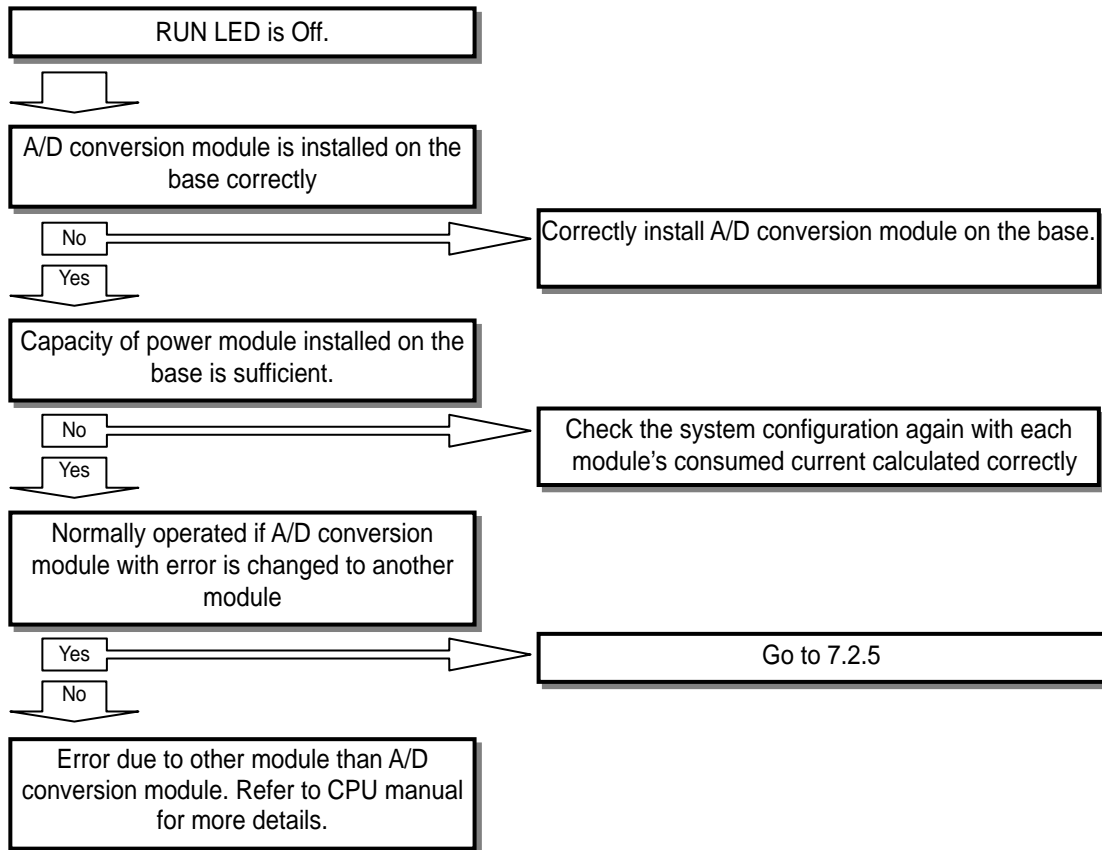

7.2.3 CPU module cannot read A/D converted value

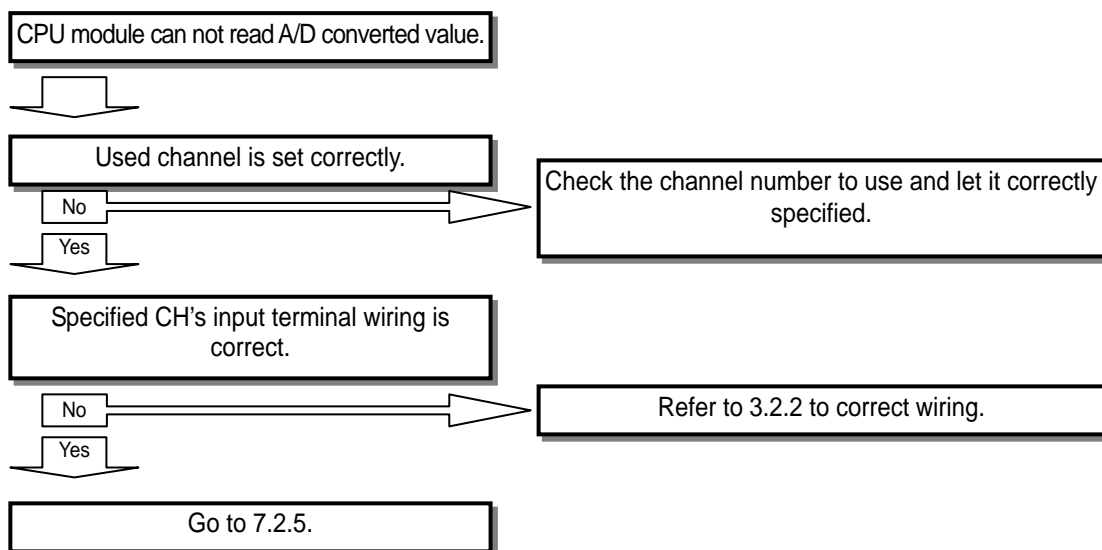

### 7.2.4 Relationship discordant between analog input value & digital output value

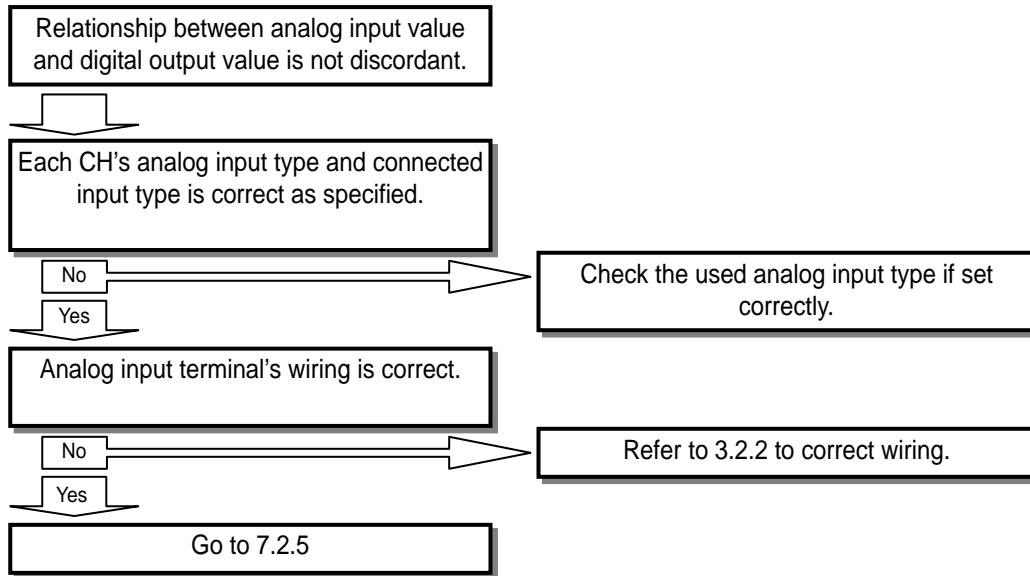

### 7.2.5 H/W error of A/D conversion module

Let the power ON/OFF again. If the error occurs again, it seems to be a module defect. Contact the nearest agency or LS branch office.

### 7.2.6 Status check of A/D conversion module through XG5000 system monitor

Module type, module information, O/S version and module status of A/D conversion module can be checked through XG5000 system monitoring function.

#### 1) Execution sequence

Two routes are available for the execution.

- (1) [Monitor] -> [System Monitoring] -> And on the module screen, click the right mouse button to display [Module Information].
- (2) [Monitor] -> [System Monitoring] -> And Double-click the module screen.

#### 2) Module information

- (1) Module type: shows the information of the module presently installed.
- (2) Module information: shows the O/S version information of A/D conversion module.
- (3) O/S version: shows the O/S prepared date of A/D conversion module.
- (4) Module status: shows the present error code. (Refer to 7.1 for detailed error codes)

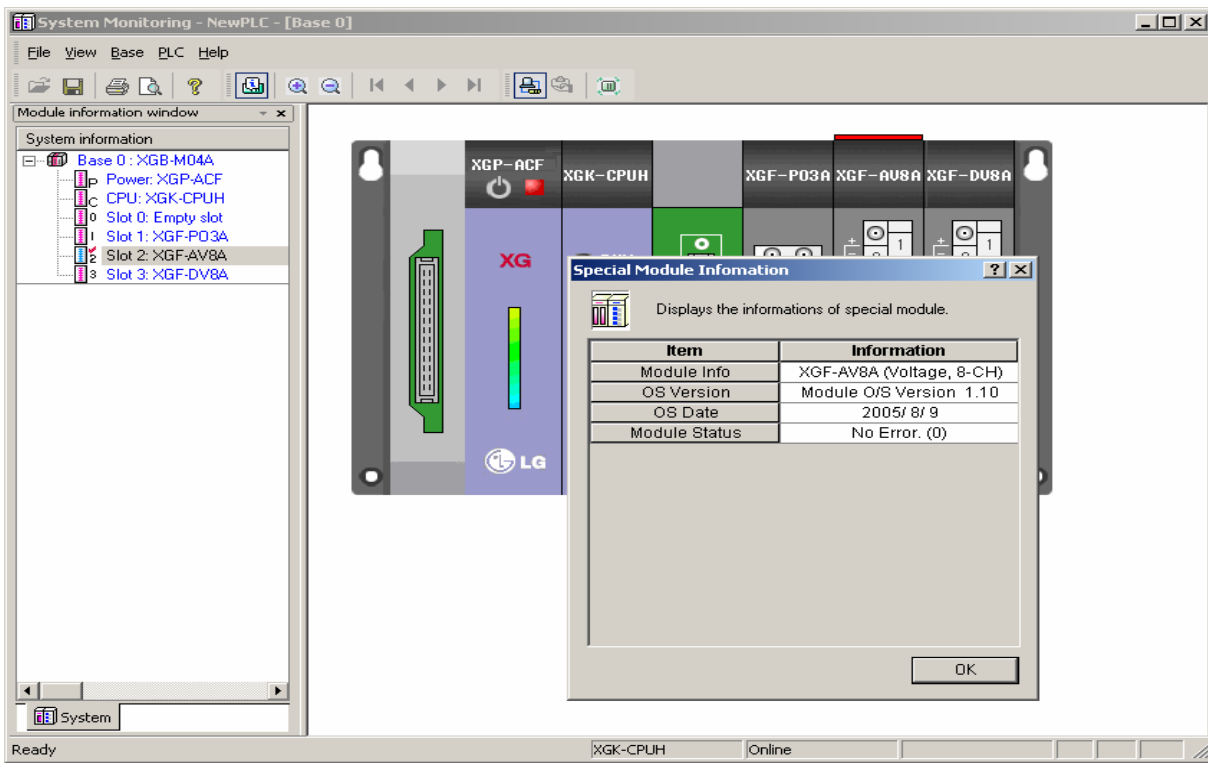

## Appendix 1 Terminology

Terms and abbreviation used in the user's manual and the analog module in general are as described below.

- A/D converter: converts analog to digital value proportionately to the size of analog input signal.
- Analog input module: as a module with the circuit to convert analog voltage/current input signal to digital value, it has resolution of 14 and 16 bits according to converters.
- Channel: related with the terminal of analog I/O module and connected to various voltage/current I/O devices respectively, with applicable data and diagnosis function as well.
- Conversion time: time necessary for analog input module to sample and convert the analog signal for the processor inside the module to get digital-converted value input. On the other hand, it is time necessary for analog output module to convert the digital value output from the processor inside the module to analog output signal so to transmit to the output channel.
- D/A converter: related with the output module, it is used to make continuous size of analog voltage and current signal proportionately to the digital value.
- Full scale: defined as the size of voltage/current where the normal operation is executed.
- Full scale error: displayed with graph difference between agreeable analog-converted value and actual analog-converted value.
- Full scale range: displayed with difference between the maximum and the minimum of the analog input.
- LSB (Least Significant Bit): displays the min. value of the bit unit.

## Appendix

---

■ Linearity error: analog I/O is related between continuous voltage/current value and digital value, whose agreeable I/O value is defined as a line within a distance of the min. 1LSB of voltage/current. I/O linearity error is regarded as the declination between the agreeable-converted value and the actual-converted value on the graph.

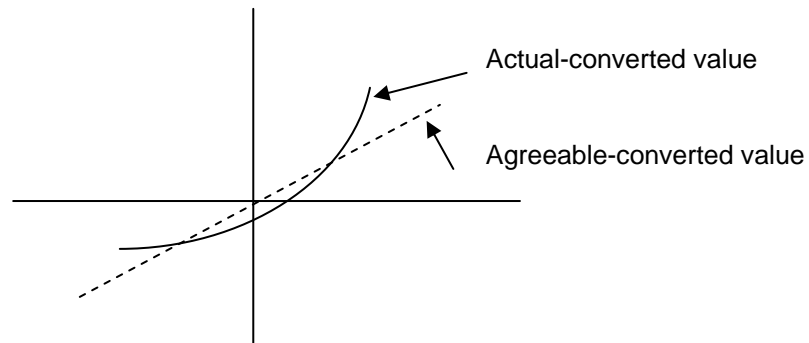

■ Multiplexer: a switching circuit where many signals share one A/D converter or D/A converter.

■ Analog output module: a module with output circuit to convert analog DC voltage or current signal proportionate to digital value delivered to the module from the processor.

■ Resolution: the min. value recognizable by a measuring instrument, which is usually displayed in the engineering unit (1mv) or the number of bits. In other words, 16383 types of output are available for 14 bits.

■ Filter: used to reduce the change of the digital-converted value output by sudden change of the external noise or input for the analog circuit, through two methods of S/W and H/W filters.

■ Accuracy: displayed with the max. declination between agreeable value and output voltage or current for the whole range of output. On the other hand, it is displayed with the max. declination between agreeable value and digital-converted input signal value for the whole range of input. Generally, percentage will be displayed for the full scale.

Gain, Offset and Linearity error are all included in the error type available.

■ Output accuracy: displayed with the difference between the actual analog output voltage/current value and the agreeable-converted value on the conversion graph for the full scale, with Offset, Gain and Drift error factors included as well as normal temperature (25°C) and available temperature range displayed respectively.

**Appendix 2 External Dimensions**

**1) External dimensions of XGF-AV8A/AC8A**

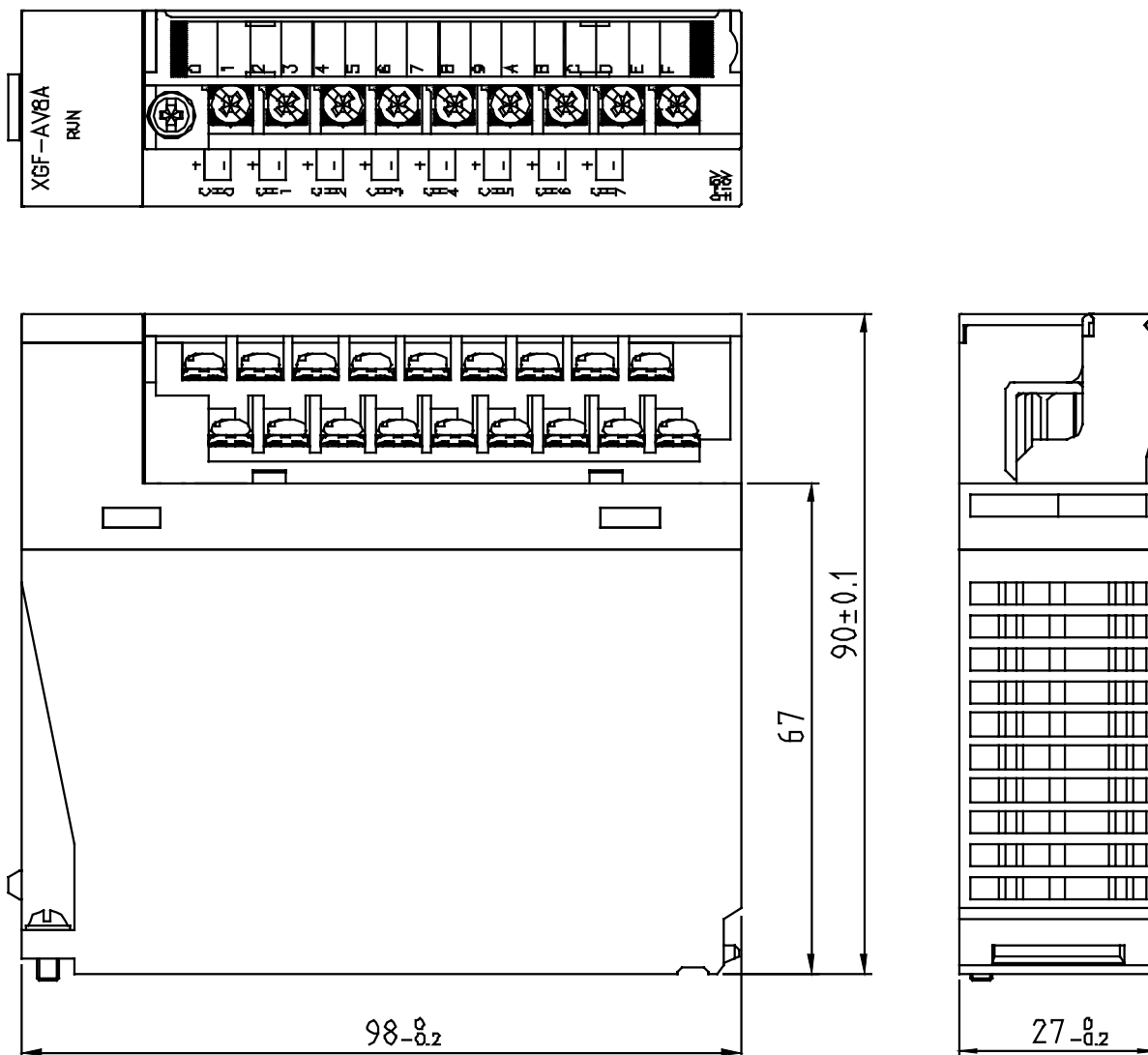

<b>Index</b>
--------------

**A**

Accuracy..... 2-13  
 A/D conversion module..... 1-1  
 Analog input points..... 2-2  
 Analog quantity.....1-2  
 Average process..... 2-16

**B ~ C**

**D**

Digital output value ..... 5-3  
 Digital value ..... 1-2

**E**

Error code ..... 5-2, 5-10

**F**

Filter constant..... 2-15, 5-7  
 Filter process..... 2-15  
 Flag to detect disconnection..... 5-1, 5-4  
 Flag to request error clear ..... 5-4  
 Count average process..... 2-17  
 Function to detect input disconnected... 2-17

**G**

Gain value..... 2-3  
 GET ..... 6-1  
 GETP ..... 6-1  
 GUI ..... 1-1

**H**

**I**

IEC ..... 2-1  
 Internal-consumed current..... 2-2  
 I/O parameter ..... 4-2

**J ~ L**

**M**

Max. conversion speed..... 2-2  
 Module Ready/Error flag ..... 5-3

Start Monitoring ..... 4-11

**N ~ O**

Offset value..... 2-3

**P**

Percentile value..... 2-6, 2-11  
 Performance specifications ..... 2-2  
 Pollution level..... 2-1  
 Precaution for handling ..... 3-1  
 Precise value..... 2-6, 2-11  
 PUT ..... 6-2  
 PUTP ..... 6-2

**Q**

**R**

Reset Max./Min. .... 4-13  
 Resolution ..... 1-1, 2-2  
 Respective designations and functions..... 2-4  
 Run channel flag ..... 5-3  
 RUN LED ..... 2-4, 5-10

**S**

Sampling process..... 2-15  
 Signed value ..... 2-6, 2-11  
 Special module monitoring ..... 4-8, 4-10

**T**

Test ..... 4-12  
 Time average process..... 2-16

**U**

Unsigned value ..... 2-6, 2-11

**V ~ W**

**X**

XGF-AC8A ..... 1-1  
 XGF-AV8A ..... 1-1  
 XGT ..... 1-1

---

## Warranty

### 1. Terms of warranty

LSIS provides an 18-month warranty starting from the date of production.

### 2. Range of warranty

For problems within the terms of the warranty, LSIS will replace the entire PLC or repair the defective parts free of charge except for the following cases.

- (1) Problems caused by improper conditions, environment or treatment.
- (2) Problems caused by external devices.
- (3) Problems caused by the user remodeling or repairing the PLC.
- (4) Problems caused by improper use of the product.
- (5) Problems caused by circumstances where the expectations exceed that of the science and technology level when LSIS produced the product.
- (6) Problems caused by natural disaster.

### 3. This warranty is limited to the PLC itself only. It is not valid for the whole system which the PLC is attached to.