

# User Manual

## RS485 Option Board SV-IP5A



- Be sure to read “Safety Instructions” before using for the proper use.
- Keep this manual within easy reach for quick reference.

## SAFETY PRECAUTIONS

- Always follow safety precautions to prevent accidents and potential hazards from occurring.
- In this manual, safety messages are classified as follows:



### WARNING

Improper operation may result in serious personal injury or death.



### CAUTION

Improper operation may result in slight to medium personal injury or property damage.

- Throughout this manual we use the following two illustrations to make you aware of safety considerations:



Identifies potential hazards under certain conditions

Read the message and follow the instructions carefully.



Identifies shock hazards under certain conditions

Particular attention should be directed because dangerous voltage may be present.

- Keep operating instructions handy for quick reference.
- Read this manual carefully to maximize the performance of LS485/Modbus-RTU/Metasys-N2 for SV-iP5A series inverters and ensure its safe use.



## CAUTION

- **Be cautious, when handling the CMOS components of the Option Board.**  
Static may lead to malfunctioning of the product.
- **Turn off the inverter power, when changing the communication cable.**  
Otherwise, you may damage the board or a communication error may occur.
- **Make sure to insert the Option Board connector to the inverter precisely.**  
Otherwise, you may damage the board or a communication error may occur.
- **Check the parameter unit before setting up the parameter.**  
Otherwise, a communication error may occur.

# Table of Contents

<b>1. Introduction</b>	<b>1</b>
1.1 Features	4
1.2 Before Installation	4
<b>2. Specification</b>	<b>4</b>
2.1 Performance specification	4
2.2 Hardware Specifications	4
2.3 Communication Specification	5
<b>3. Product Details</b>	<b>5</b>
3.1 RS485 Option Board Layout and Names of Part	5
3.2 Status LED	5
3.3 Termination Configuration	6
3.4 Communication Protocol Selection (LS485/Modbus-RTU/Metasys-N2)	6
<b>4. Installation</b>	<b>7</b>
4.1 Installing RS485 Option Board and Parameter setting	7
4.2 Connection Guide for the Communication Option Board, the Computer and the Converter	10
<b>5. Communication protocol</b>	<b>10</b>
5.1 LS485 Protocol	10
5.1.1 Basic format	10
5.1.2 Detailed Read protocol	11
5.1.3 Detailed Write protocol	12
5.1.4 Detailed Monitor Register protocol	12
5.1.5 Error code	13
5.2 Modbus-RTU Protocol	14
5.2.1 Available function code	14
5.2.2 Exception code	14
5.3 Baud Rate	14
5.4 Broadcast Function	14
<b>6. Trouble shooting</b>	<b>14</b>
<b>7. Parameter Code (All parameter addresses are Hex. values)</b>	<b>15</b>
7.1 SV-iP5A Common Area	15
7.2 Metasys-N2 Protocol I/O Point Map	17
7.2.1 Analog Output	17
7.2.2 Binary Output	18
7.2.3 Analog Input	18
7.2.4 Binary Input	19

# 1. Introduction

This instruction manual describes about specification and how to set up the RS485 option board for SV-iP5A inverter to communicate with PLC or PC. SV-iP5A series inverter can be controlled and monitored by PLC , PC and other master module with RS485 option board.

## 1.1 Features

Inverter can be easily applicable to Factory Automation because operation and monitoring is available by User-program.

\* Parameter setting and monitoring is available via computer.

(Ex: Freq. Command, Run/Stop etc.)

\* Interface type of RS485 reference:

- 1) Allows the inverter to communicate with any other computers.
- 2) Allows one computer to control up to 31 inverters with multi-drop link system.
- 3) Noise-resistant interface.

Users can use any kind of RS232/485 converters. It is possible to communicate with computer which has built-in type of RS232 board. The specifications and performances of converters depend on the manufacturers, but the basic functions are the same. Refer to the converter manual for detailed specifications and instructions on how to use.

## 1.2 Before Installation

Before installation and operation, this manual should be read thoroughly. If not, it could cause personal injury or damage other equipment.

# 2. Specification

## 2.1 Performance specification

Items	Specifications
Communication method	RS485 (RS232/485 converter)
Transmission form	Bus method, Multi-drop Link System
Applicable inverter	SV-iP5A series
Converter	Converter with RS232 board embedded
Number of inverters connected	Maximum 31 inverters connectable <sup>1</sup>
Transmission distance	Max. 1200m (Less than 700m recommended) <sup>2</sup>

## 2.2 Hardware Specifications

Items	Specifications	
Installation	Use option connector on the inverter control board	
Power Supply	Control Board	From inverter power supply (5V)
	Communication Board	From control board (5V)

<sup>1</sup> The number of inverters to be connected is up to 31.

<sup>2</sup> The specification of length of the communication cable is max. 1200m. To ensure stable communication, limit its length below 700m.

## 2.3 Communication Specification

Items	Specifications
Communication speed	1200 /2400/4800/9600/19200/38400/76800/115200 bps <sup>3</sup>
Control procedure	Asynchronous communication system
Communication system	Half-duplex system
Character system	LS485: ASCII(8bit) Modbus-RTU: Binary (8 bit) Metasys-N2: ASCII (8 bit)
Start/Stop bit	Start 1bit, Stop 1/2bit
Error check	LS485 : Checksum (2 byte) Modbus-RTU: CRC16 (2 byte) Metasys-N2: CRC 16 (2 byte)
Parity check	None/Even/Odd <sup>4</sup>

## 3. Product Details

### 3.1 RS485 Option Board Layout and Names of Part

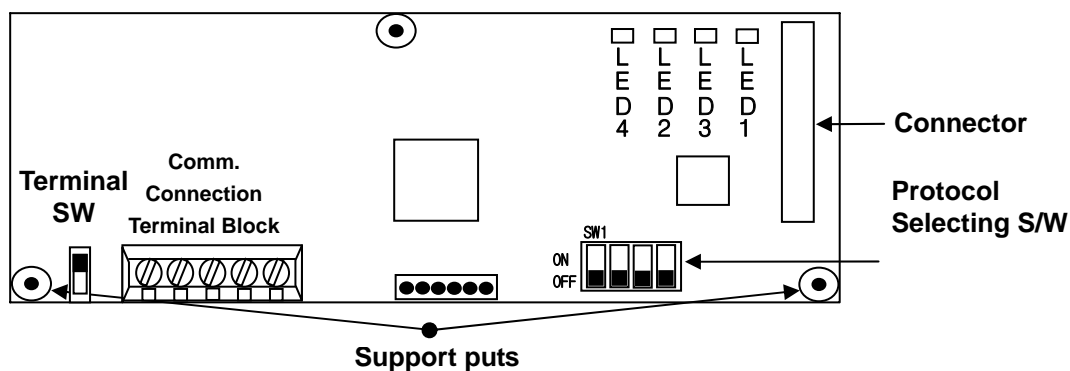





Figure 1. Layout and Names of Part

### 3.2 Status LED

Red	Green	Green	Green
Error	TXD	RXD	CPU
			

<b>CPU LED (LED1)</b>	Indicates the option board works normally.	
<b>RXD LED (LED3)</b>	Receiving communication signal	
<b>TXD LED (LED2)</b>	Transmitting communication signal	
<b>ERR LED (LED4)</b>	Blinking intermittently	Receiving wrong DATA (Normal operation)
	Blinking simultaneously with CPU LED	Communication malfunction between inverter and option board
	Blinking oppositely to CPU LED	Network Connection Time Out

<sup>3</sup> Metasys-N2: Fixed 9600 bps

<sup>4</sup> Metasys-N2: Fixed No Parity

### 3.3 Termination Configuration

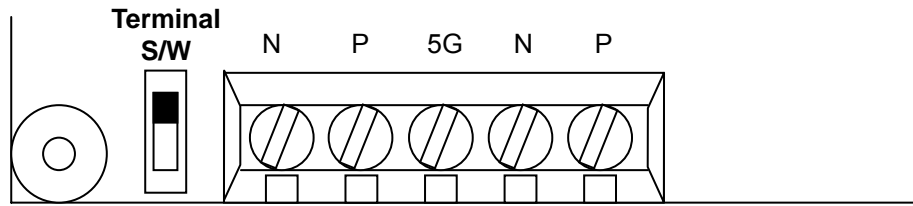

Figure 2. Communication Terminal Block

Pin	5G	GND	N	P
Role	Signal Ground	Ground	Signal line	

5G : Ground of communication terminal.

Terminal S/W: Inverter at the end of the network must turn On the S/W.

### 3.4 Communication Protocol Selection (LS485/Modbus-RTU/Metasys-N2)

- Setting method

The Modbus-RTU protocol is selected when the No.1 (among the DIP switches located on the lower right corner of the option board) is ON, and LS485 protocol is selected when the No.1 is OFF. SV-iP5A series have the same setting.

(At this time the On/Off status of the No.3, 4 DIP switches has not an effect on the protocol selection.)

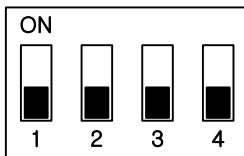

→ LS485 protocol selection

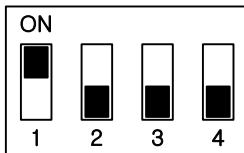

→ Modbus-RTU protocol selection

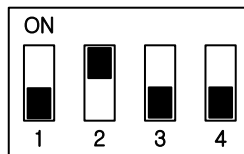

→ Metasys-N2 Protocol selection

- Precautions when setting

Even if the Master's protocol is changed during communication between Master and slaves (LS Inverters), selected protocol will be applied after that set the DIP switch on option board as above and set the Comm Update of COM group to 'YES'.

## 4. Installation

### 4.1 Installing RS485 Option Board and Parameter setting

- ① Connect RS485 option board connector to the option connector inside the inverter control board. (See Figure 3 and 4). Make sure that the support is well connected. If the position of the support is not right, it means that the option board is not connected correctly.
- ② Power up the inverter after verifying the option board is installed properly.
- ③ When powering up the inverter, CPU LED is blinking per second after all LEDs blink one after another.
- ④ If 'CPU LED' is not blinking, power down the inverter swiftly and check for the proper installation of the option board.

(**Caution:** The inverter and option board may get damaged in case that power is applied to the inverter for a long time when CPU LED is not blinking.)

\* If this problem occurs continuously, contact LS distributors.

- ⑤ Check displayed < COM-01 > for SV-iP5A is set to RS485.
- ⑥ Set the parameters as below when the above steps are all done.

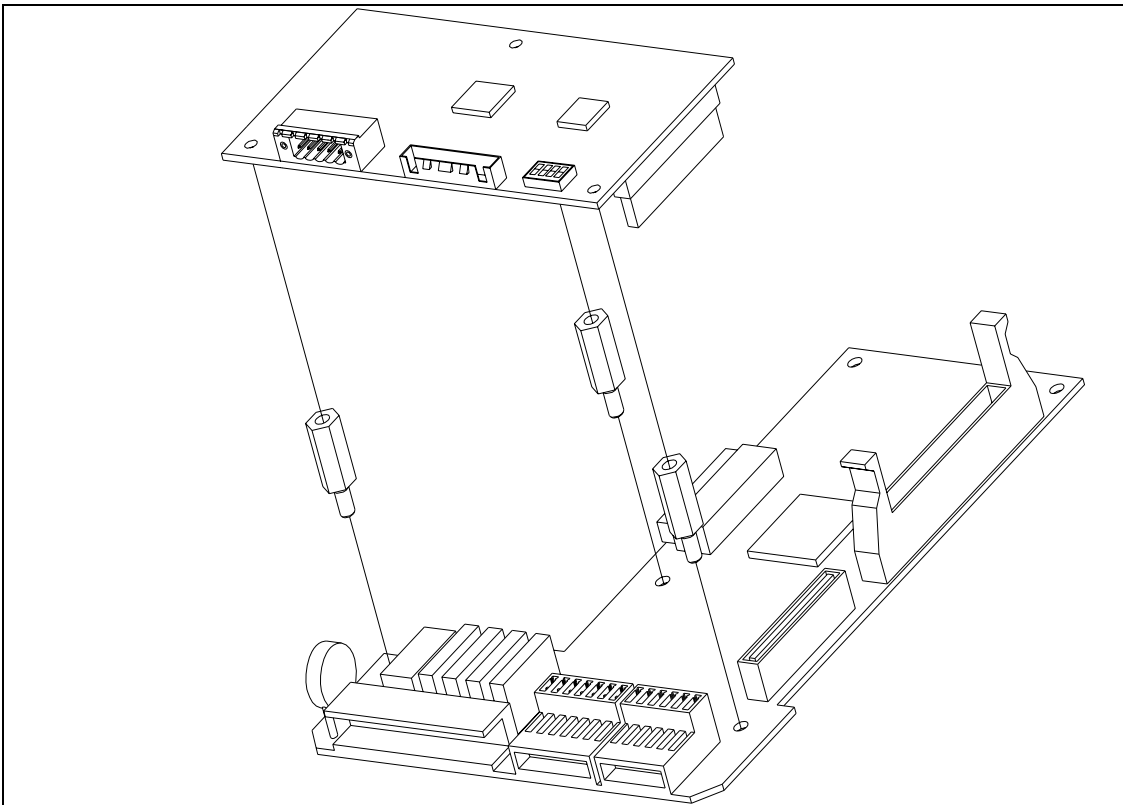

Figure 3. SV-iP5A RS485 Option Board Installation

## 1. LS485, Modbus-RTU Setting <sup>5</sup>

Parameter code	Display	Setting Value
I/O- 92	COM Lost Cmd <sup>6</sup>	0 : None 1 : FreeRun 2 : stop
COM-01	Opt B/D	RS485 displayed automatically
COM-02	Opt mode	Set Commands controlled via communication 0: None (Not set Run/Freq. command via communication) 1: Command (Set Run command via communication) 2: Freq (Set Freq. commands via communication) 3 : Cmd+Freq (Set Run/Freq. command via communication)
COM-61	Inv. No.	1 ~ 250 1: Factory Default (Verify the assigned number is not duplicated)
COM-62	Baud rate	0 : 1200 bps 1 : 2400 bps 2 : 4800 bps 3 : 9600 bps (Factory Default) 4 : 19200 bps 5 : 38400 bps 6 : 76800 bps 7 : 115200 bps
COM-63	Parity/Stop	0 : 1 Stop bit, No Parity (Factory Default) 1 : 2 Stop bit, No Parity 2 : 1 Stop bit, Even Parity 3 : 1 Stop bit, Odd Parity
COM-64	Delay Time	0 ~ 100 msec 5mmsec:Factory Default
COM-65	COM Time Out <sup>7</sup>	0.1 ~ 120 sec 1.0 sec (Factory Default)
COM-67	Comm UpDate	After Comm Update set to 'Yes', it is changed to 'No' automatically.

<sup>5</sup> It is applied after 'COMM Update' of COM-67 setting is changed 'Yes' mode.

<sup>6</sup> When inverter and master's communication is not completed, this command is used for emergency stop. This action means inverter is not controlled by remote control. For the safety operation, set this value.

<sup>7</sup> If communication between master and inverter is not connected for the setting time, inverter will be stop according to 'COM Lost Cmd' setting.

## 2. Metasys-N2 Setting<sup>8</sup>

Parameter code	Display	Setting Value
I/O- 92	COM Lost Cmd <sup>9</sup>	0 : None 1 : FreeRun 2 : stop
COM-01	Opt B/D	RS485 displayed automatically
COM-02	Opt mode	Set Commands controlled via communication 0: None (Not set Run/Freq. command via communication) 1: Command (Set Run command via communication) 2: Freq (Set Freq. commands via communication) 3 : Cmd+Freq (Set Run/Freq. command via communication)
COM-61	Inv. No.	1 ~ 250 1: Factory Default (Verify the assigned number is not duplicated)
COM-62	COM Time Out <sup>10</sup>	0.1 ~ 120 sec 1.0 sec (Factory Default)
COM-67	Comm UpDate	After Comm Update set to 'Yes', it is changed to 'No' automatically.

⑦ Turn Off the inverter power for the connection of converter after option board installation and parameter setting.

⑧ In case of option board used on terminal, terminal switch is turned On according to Figure 2.

<sup>8</sup> It is applied after 'COMM Update' of COM-67 setting is changed 'Yes' mode.

<sup>9</sup> When inverter and master's communication is not completed, this command is used for emergency stop. This action means inverter is not controlled by remote control. For the safety operation, set this value.

<sup>10</sup> If communication between master and inverter is not connected for the setting time, inverter will be stop according to 'COM Lost Cmd' setting.

## 4.2 Connection Guide for the Communication Option Board, the Computer and the Converter

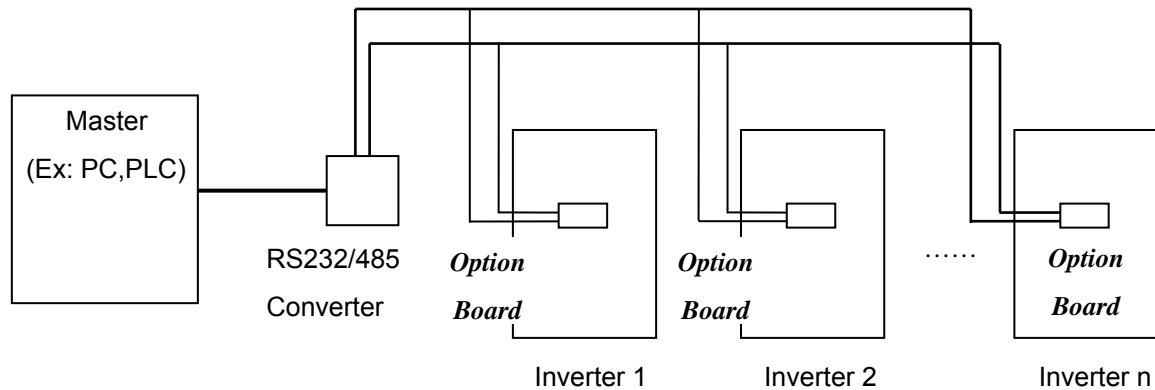

Figure 5. Communication System Configuration

## 5. Communication protocol

- Use LS485 protocol (for LS only) and Modbus-RTU protocol. LS485 and Modbus-RTU protocol are Open protocol. For more information, contact LS distributor.
- Computer or other host acts as Master while inverters act as slaves. The inverter responds to Read/Write command from Master.

### 5.1 LS485 Protocol

#### 5.1.1 Basic format

- Command message (Request):

ENQ	Inverter No.	CMD	Data	SUM	EOT
1 byte	2 byte	1 byte	n byte	2 byte	1 byte

- Normal response (Acknowledge Response):

ACK	Inverter No.	CMD	Data	SUM	EOT
1 byte	2 byte	1 byte	n * 4 byte	2 byte	1 byte

- Negative response (Negative Acknowledge Response):

NAK	Inverter No.	CMD	Error code	SUM	EOT
1 byte	2 byte	1 byte	2 byte	2 byte	1 byte

- Description:

- \* Request starts with 'ENQ' and ends with 'EOT'.
- \* Acknowledge Response starts with 'ACK' and ends with 'EOT'.
- \* Negative Acknowledge Response starts with 'NAK' and ends with 'EOT'.
- \* 'Inverter Number' represents the number of Inverters and indicates in 2 byte ASCII-HEX. (ASCII-HEX: Hexadecimal consists of '0' ~ '9', 'A' ~ 'F')

\* CMD: Capital letter ('IF Error' when small letter is used.)

Character	ASCII-HEX	Command
'R'	52h	Read
'W'	57h	Write
'X'	58h	Request for Monitor Register
'Y'	59h	Execution for Monitor Register

\* Data: ASCII-HEX

Ex) when data value is 3000: 3000 → '0' 'B' 'B' '8' h → 30h 42h 42h 38h

\* Error code: ASCII (20h ~ 7Fh)

\* Receive/Send buffer size: Receive= 39 byte, Send=44 byte

\* Monitor register buffer: 8 Word

\* SUM: to check the communication error

SUM= ASCII-HEX format of lower 8 bit of (Inverter No. + CMD + DATA)

Ex) Command Message (Request) for reading one address from address '3000'

ENQ	Inverter No.	CMD	Address	Number of address	SUM	EOT
05h	'01'	'R'	'3000'	'1'	'AC'	04h
1	2	1	4	1	2	1

SUM = '0' + '1' + 'R' + '3' + '0' + '0' + '0' + '1'  
 = 30h + 31h + 52h + 33h + 30h + 30h + 30h + 31h  
 = 1A7h (Except Control value: ENQ, ACK, NAK, etc.)

### 5.1.2 Detailed Read protocol

\* Request for Read: Request for reading Word data of the successive 'n' number from address 'XXXX'

ENQ	Inverter No.	CMD	Address	Number of Address	SUM	EOT
05h	'01' ~ '1F'	'R'	'XXXX'	'1' ~ '8' = n	'XX'	04h
1	2	1	4	1	2	1

Total byte = 12, The quotation marks (' ') mean character.

● Acknowledge Response:

ACK	Inverter No.	CMD	Data	SUM	EOT
06h	'01' ~ '1F'	'R'	'XXXX'	'XX'	04h
1	2	1	N * 4	2	1

Total byte = 7 + n \* 4 = Max. 39

● Negative Acknowledge Response:

NAK	Inverter No.	CMD	Error code	SUM	EOT
15h	'01' ~ '1F'	'R'	'**'	'XX'	04h
1	2	1	2	2	1

Total byte = 9

### 5.1.3 Detailed Write protocol

- Request for Write:

ENQ	Inverter No.	CMD	Address	Number of Address	SUM	EOT	EOT
05h	'01' ~ '1F'	'W'	'XXXX'	'1' ~ '8' = n	'XXXX...'	'XX'	04h
1	2	1	4	1	n * 4	2	1

Total byte = 12 + n \* 4 = Max. 44

- Acknowledge response:

ACK	Inverter No.	CMD	Data	SUM	EOT
06h	'01' ~ '1F'	'W'	'XXXX...'	'XX'	04h
1	2	1	n * 4	2	1

Total byte = 7 + n \* 4 = Max. 39

- Negative response:

NAK	Inverter No.	CMD	Error code	SUM	EOT
15h	'01' ~ '1F'	'W'	'**'	'XX'	04h
1	2	1	2	2	1

Total byte = 9

### 5.1.4 Detailed Monitor Register protocol

- \* Request for Monitor Register:

Monitor Register has the function to update data periodically after assigning the necessary data to be monitored continuously.

- Request for registering the 'n' number of Address (non-successive)

ENQ	Inverter No.	CMD	Number of Address	Address	SUM	EOT
05h	'01' ~ '1F'	'X'	'1' ~ '8'=n	'XXXX...'	'XX'	04h
1	2	1	1	n * 4	2	1

Total byte = 8 + n \* 4 = Max 40

- Acknowledge Response:

ACK	Inverter No.	CMD	SUM	EOT
06h	'01' ~ '1F'	'X'	'XX'	04h
1	2	1	2	1

Total byte = 7

- Negative Acknowledge Response:

NAK	Inverter No.	CMD	Error code	SUM	EOT
15h	'01' ~ '1F'	'X'	'**'	'XX'	04h
1	2	1	2	2	1

Total byte = 9

\* Action Request for Monitor Register:

- Request for reading data of address registered by Monitor Register.

ENQ	Inverter No.	CMD	SUM	EOT
05h	'01' ~ '1F'	'Y'	'XX'	04h
1	2	1	2	1

Total byte = 7

- Acknowledge response:

ACK	Inverter No.	CMD	Data	SUM	EOT
06h	'01' ~ '1F'	'Y'	'XXXX...'	'XX'	04h
1	2	1	n * 4 byte	2 byte	1 byte

Total byte = 7 + n \* 4 = Max 39

- Negative response:

NAK	Inverter No.	CMD	Error code	SUM	EOT
15h	'01' ~ '1F'	'Y'	'**'	'XX'	04h
1	2	1	2	2	1

Total byte = 9

### 5.1.5 Error code

Error code	Display	Description
ILLEGAL FUNCTION	IF	When the command received cannot be executed in the option board. It means that there is no corresponding command.
ILLEGAL DATA ADDRESS	IA	When parameter address received is invalid. When monitor is executed without Monitor Register.
ILLEGAL DATA VALUE	ID	When the DATA received is invalid.
WRITE MODE ERROR	WM	In case of Read Only or Write Disabled during operation.
FRAME ERROR	FE	When the frame size, internal Num or Sum is incorrect.
TIME OUT ERROR	TO	When DPRAM communication does not work within a certain time.
DPRAM OFF LINE	DO	When DPRAM is Off Line.
INVALID ID NUMBER	IN	When Inverter Number is incorrect.
UNDEFINED CONDITION	UC	Except for the above cases.

- ※ TO Error: Occurs when trying to communicate while the inverter is initializing. The inverter cannot respond while the inverter is initializing. After initialization, it operates normally.

## 5.2 Modbus-RTU Protocol

Use Modbus-RTU protocol. Modbus-RTU protocol is Open protocol.

Computer or other host acts as Master while inverter act as slaves. The inverter responds to Read/Write command from Master.

### 5.2.1 Available function code

Function code	Description
0x03	Read Hold Register
0x04	Read Input Register
0x06	Preset Single Register
0x10	Preset Multiple Register

### 5.2.2 Exception code

Exception code	Description
0x01	ILLEGAL FUNCTION
0x02	ILLEGAL DATA ADDRESS
0x03	ILLEGAL DATA VALUE
0x06	SLAVE DEVICE BUSY
User define	0x14 1. Write Disable (Address 0x0004 value is 0). 2. Read Only or Not Program during Running.

## 5.3 Baud Rate

1200, 2400, 4800, 9600, 19200, 38400, 76800, 115200 bps (Default value: 9600bps)

## 5.4 Broadcast Function

The broadcast function is used when command is given to all inverters connected to network.

\* In the case of LS485, all inverters run without response (Slave->Master) when command is given to Inverter Number 255 (0xFF).

\* In the case of Modbus-RTU, all inverters run without response (Slave->Master) when command is given to Inverter Number 0 (0x00).

## 6. Trouble shooting

Refer to this chapter when occurring problem in communication with computer while using this option board.

- CPU LED malfunction

<b>Expected State</b>	The inverter is not working normally or the inverter and the option board are not connected properly.
<b>Corrective Measures</b>	1. Verify the power is applied to the inverter. 2. Verify the option board is installed properly within the inverter when the inverter is working normally.

- RXD and TXD LEDs malfunction

Check Points	Corrective Measures
Is the power applied to the converter?	Apply power to the converter.
Is the connection between the converter and computer correct?	Refer to the converter manual

Check Points	Corrective Measures
Is the communication board installed within the inverter properly?	Refer to '4 Installation'.
Does Master start the communication?	Start the communication.
Is the communication speed setting of the inverter correct?	Refer to '4 Installation'.
Is the data format of User program correct?	Modify User program <sup>11</sup>
Is the connection between the converter and the option board correct?	Refer to '4. Installation'.

- ERR LED is working

State	Corrective Measures
Blinking intermittently	In case that the option board is receiving wrong data due to Noise or other causes. It is normal.
Blinking oppositely to CPU LED	Network is not communicated during Time Out setting. Verify the state of Master. (LS485, Modbus-RTU: COM-65, Metasys-N2: COM-62)
Blinking simultaneously CPU LED	In case of occurring the communication trouble between the option board and the inverter. Power up and down the inverter. If this problem occurs continuously, contact LS distributor.
● Concerning the frequency (speed)/Run command by the option board, please refer to COM group for SV-iP5A.	

## 7. Parameter Code (All parameter addresses are Hex. values)

**Common Area:** Common Area is addresses to be used commonly regardless of inverter models. Some addresses are used only for specific inverter models. <sup>12</sup>

### 7.1 SV-iP5A Common Area

Address	Parameter	Unit	R/W	Data value
0x0000	Inverter model	-	R	9 : SV-iP5A
0x0001	Inverter capacity	-	R	SV-iP5A 4: 5.5            5: 7.5            6: 11            7: 15 8: 18.5           9: 22            A: 30            B: 37 C: 45            D: 55            E: 75            F: 90 10: 110           11: 132           12: 160           13: 220 14: 280           15: 315           16: 375           17: 450 (Unit : kW)
0x0002	Inverter	-	R	0: 220V Class    1: 440V Class
0x0003	S/W Version	-	R	0100h : Ver 1.00,    0110h : Ver 1.10
0x0005	Freq. Command	0.01Hz	R/W	
0x0006	Run/Stop Command	-	R/W	BIT 0   Stop BIT 1   Forward Run (FX) BIT 2   Reverse Run (RX) BIT 3   Fault Reset (0→1) BIT 4   Emergency Stop BIT 5   Not Used

<sup>11</sup> User program is User-made S/W for PC.

<sup>12</sup> When the data is changed by Common Area parameter, its data is not saved.

That is, the changed data is effective in the present state but the data is reset to the previous value after the inverter is reset or powered On / Off. Even though the inverter is reset or powered On / Off, the changed data is effective in case of changing the data by each group parameter, not the Common Area.

Address	Parameter	Unit	R/W	Data value			
			R	BIT 6	Run/Stop Command Information	0	Terminal block
						1	Loader
						2	Option
				BIT 7		3	Int. 485
						0~16	Multi-step Speed Freq. (0.2~16)
				BIT 8		17~19	UpDown Operation (Up, Down, UD Zero)
						20~21	Not used
				BIT 9	Freq. Command Information	22~25	Analog Operation ( V1, V1S, I, V1I )
				BIT 9		26	Pulse
						27	Sub
				BIT 10		28	Int. 485
						29	Option
				BIT 11		30	Jog
						31	PID
				BIT 12			
BIT 13	Not Used						
BIT 14	Not Used						
BIT 15	Set when Network malfunction occurs						
0x0007	Acceleration Time	0.1 sec	R/W				
0x0008	Deceleration Time	0.1 sec	R/W				
0x0009	Output Current	0.1 A	R				
0x000A	Output Frequency	0.01 Hz	R				
0x000B	Output Voltage	0.1 V	R				
0x000C	DC Link Voltage	0.1 V	R				
0x000D	Output Power	0.1 kW	R				
0x000E	Operating Status	-	R	BIT 0	Stop		
				BIT 1	Forward Run (FX)		
				BIT 2	Reverse Run (RX)		
				BIT 3	Fault (Trip)		
				BIT 4	Accelerating		
				BIT 5	Decelerating		
				BIT 6	Speed Arrival		
				BIT 7	Forward Command		
				BIT 8	DC Braking		
				BIT 9	Not Used		
				BIT10	Brake Open		
				BIT11	Forward Run Command		
				BIT12	Reverse Run Command		
				BIT13	REM. R/S (Int. 485, OPT)		
				BIT14	REM. Freq. (Int. 485, OPT)		
BIT15	Not Used						
0x000F	Trip Information	-	R	BIT 0	OCT1		
				BIT 1	OV		
				BIT 2	EXT-A		
				BIT 3	BX		
				BIT 4	LV		
				BIT 5	Not Used		
				BIT 6	GF(Ground Fault)		
				BIT 7	OH (Inverter overheat)		

Address	Parameter	Unit	R/W	Data value	
				BIT 8	ETH (Motor overheat)
				BIT 9	OLT (Overload trip)
				BIT10	HW-Diag
				BIT11	Not Used
				BIT12	OCT2
				BIT13	OPT (Option error)
				BIT14	PO (Phase Open)
				BIT15	IOLT
0x0010	Input Terminal Information	-	R	BIT 0	M1
				BIT 1	M2
				BIT 2	M3
				BIT 3	M4
				BIT 4	M5
				BIT 5	M6
				BIT 6	M7
				BIT 7	M8
				BIT 8	P4
				BIT 9	P5
				BIT 10	P6
				BIT11~15	Not Used
0x0010	Output Terminal Information	-	R	BIT 0	AUX1
				BIT 1	AUX2
				BIT 2	AUX3
				BIT 3	AUX4
				BIT 4	Q1 (OC1)
				BIT 5	Q2 (OC2)
				BIT 6	Q3 (OC3)
				BIT 7	30AC
				BIT 8~15	Not used
0x0012	V1	-	R	0000h ~FFC0h	
0x0013	V2	-	R	0000h ~FFC0h	
0x0014	I	-	R	0000h ~FFC0h	
0x0015	RPM	-	R		
0x001A	Unit display	-	R	0 : Hz, 1 : RPM	
0x001B	Pole number	-	R		
0x001C	Custom Version	-	R		

※ Refer to the user manual for the communication address regarding SV-iP5A Function Code.

## 7.2 Metasys-N2 Protocol I/O Point Map

### 7.2.1 Analog Output

Output point map to control the inverter from Metasys-N2 master

No.	Unit	Name	Range	Description
AO-1	Hz	Command Frequency	0.00 – Max Freq (FU1-20)	When COM02 (Opt Mode) is 'Cmd+Freq' or 'Freq', frequency can be set via N2 communication protocol. The setting value is not saved after Power Off.
AO-2	Sec	Accel Time	0.0 – 600.0	The setting value is not saved after Power Off..
AO-3	Sec	Decel Time	0.0 – 600.0	The setting value is not saved after Power Off.

No.	Unit	Name	Range	Description
AO-4	-	Drive mode	0 – KeyPad 1 – Fx/Rx-1 2 – Fx/Rx-2	When COM02 (Opt Mode) is 'Cmd+Freq' or 'Command', this setting is not valid via N2 protocol.
AO-5	-	Freq mode	0 – KeyPad-1 1 – KeyPad-2 2 – V1 3 – V1S 4 – I 5 – V1+I 6 – Pulse 7 – Int 485 8 – Ext. PID	COM02 (Opt Mode) is 'Cmd+Freq' or 'Freq', the setting is not valid via N2 protocol.

### 7.2.2 Binary Output

Output point map to control the inverter from Metasys-N2 master

No.	Name	Range	Description
BO-1	Stop	1 – Stop	If '1' inputs in BO-1 via N2 protocol, inverter will stop while running.
BO-2	Run Forward	1 – Forward Run	If '1' inputs in BO-2 via N2 protocol, inverter will run to forward direction.
BO-3	Run Reverse	1 – Reverse Run	If '1' inputs in BO-3 via N2 protocol, inverter will run to reverse direction.
BO-4	Reset Fault	1 – Reset	If '1' inputs in BO-4 via N2 protocol, inverter trip records will reset.
BO-5	Emergency Stop	1 – Bx	If '1' inputs in BO-5 via N2 protocol, inverter will change to emergency stop (BX).

### 7.2.3 Analog Input

Metasys-N2 master monitors the state of inverter.

No.	Unit	Name	Description
AI-1	Amps	Output Current	Monitoring the present output current value
AI-2	Hz	Output Frequency	Monitoring the present output frequency (Hz)
AI-3	RPM	Output Speed	Monitoring the present speed (RPM)

No.	Unit	Name	Description
AI-4	-	Fault Code	0x0000 – No fault 0x0001 – OC 0x0002 – OV 0x0004 – EXT 0x0008 – BX 0x0010 – LV 0x0020 – FUSE 0x0040 – GF 0x0080 – OH 0x0100 – ETH 0x0200 – OLT

#### 7.2.4 Binary Input

Metasys-N2 master monitors the binary input/output state of inverter.

No.	Name	Description
BI-1	Stopped	
BI-2	Running Forward	
BI-3	Running Reverse	
BI-4	Faulted	
BI-5	Accelerating	
BI-6	Decelerating	
BI-7	Reached Full Speed	
BI-8	DC Braking	
BI-9	M1 Input	
BI-10	M2 Input	
BI-11	M3 Input	
BI-12	M4 Input	
BI-13	M5 Input	
BI-14	M6 Input	
BI-15	M7 Input	
BI-16	M8 Input	
BI-17	30AC fault relay	Output state of 30AC fault relay