

DeviceNet Option Board SV-iS5,iP5A,iV5 Series



- * Use this board after read Safety Instruction of this manual carefully before using and follow the instructions exactly.
- * Please hand this user manual to end user and trouble shooting manager
- * After read this manual, keep it at handy for future reference.

LS Industrial Systems

Thank you for purchase of LS DeviceNet Option Board!

SAFETY PRECAUTIONS

- Always follow safety precautions to prevent accidents and potential hazards from occurring.
- Safety precautions are classified into “WARNING” and “CAUTION” in this manual.



WARNING

Indicates a potentially hazardous situation which, if not avoided, can result in serious injury



CAUTION

Indicates a potentially hazardous situation which, if not avoided, can result in minor to moderate injury, or serious damage to the product.

- Throughout this manual we use the following two illustrations to make you aware of safety considerations:



Identifies potential hazards under certain conditions.
Read the message and follow the instructions carefully.



Identifies shock hazards under certain conditions.
Particular attention should be directed because dangerous voltage may be present.

- Keep this manual at handy for quick reference.



CAUTION

- **Be sure to take ESD (Electrostatic Discharge) protection measures when you touch the board.**
Otherwise, the option board may get damaged due to static charges.
- **Implement wiring change on the Option Board after checking that the power supply is off.**

Otherwise, there is a danger of connecting error and damage to the board.

- **Be sure to fix inverter to option board tightly.**

Otherwise, there is a danger of connecting error and damage to the board.

- **Be sure to install a termination resistor (120ohm, 1/4W) at the end of the network.**

- **Be sure to check parameter unit when setting parameters.**

Otherwise, there is a danger of connecting error.

CHAPTER 1 - INTRODUCTION

By using a DeviceNet communication board, SV-iS5/iP5A/iV5 inverter can be connected to a DeviceNet network.

1.1. Through LS DeviceNet Option Board...

- Inverter can be controlled and monitored by PLC sequence program or any Master Module.
- Multiple inverters can be connected to one communication cable with simple and easy installation, dramatically saving wiring, maintenance cost and time.
- Compatible with PC System, PLC and any controllers is available, making Factory Automation more easily.

1.2. Kit Contents

The DeviceNet option board kit consists of DeviceNet Option Board 1 pcs, 5 pin Connector 1 pcs, Mounting poles 3 pcs and Installation Manual.

1.3. DeviceNet Option Board Specification

Items		Specification
Device Type		AC Drives
Explicit Peer to Peer Messaging		Support
I/O Peer to Peer Messaging		N/A
Configuration Consistency Value		N/A
Faulted Node Recovery(Off-Line)		Support
Baud Rate Support		125, 250, 500(kbps)
Master/Scanner (Predefined M/S Connection)		Support
I/O Slave	Polling	Support
Messaging	Bit Strobe, Cyclic, COS(Change of State)	N/A
Input Voltage Range		11 ~ 25V DC

CHAPTER 2 - LAYOUT & INSTALLING THE OPTION BOARD

2.1 Board Layout

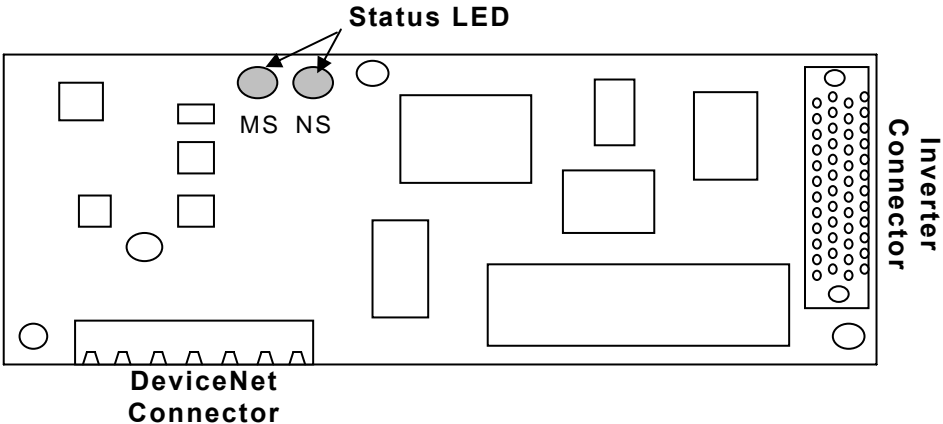

Figure 1 – Board layout

2.1.1. Status LED

MS(Module Status) LED	Checks the status of incoming power to option board, CPU function and communication to the Inverter.
NS(Network Status) LED	Checks the connection of option card on the Network and DeviceNet power status.

Note) Refer to **5-TROUBLESHOOTING** for more details.

2.1.2. DeviceNet Connection Terminal

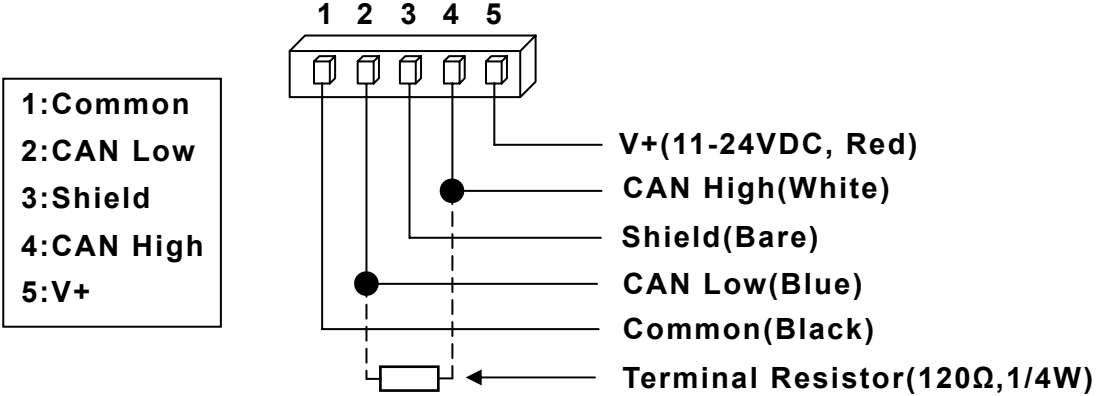

Figure 2 – DeviceNet Connection Terminal

2.2. Installing the Option Board to the Inverter

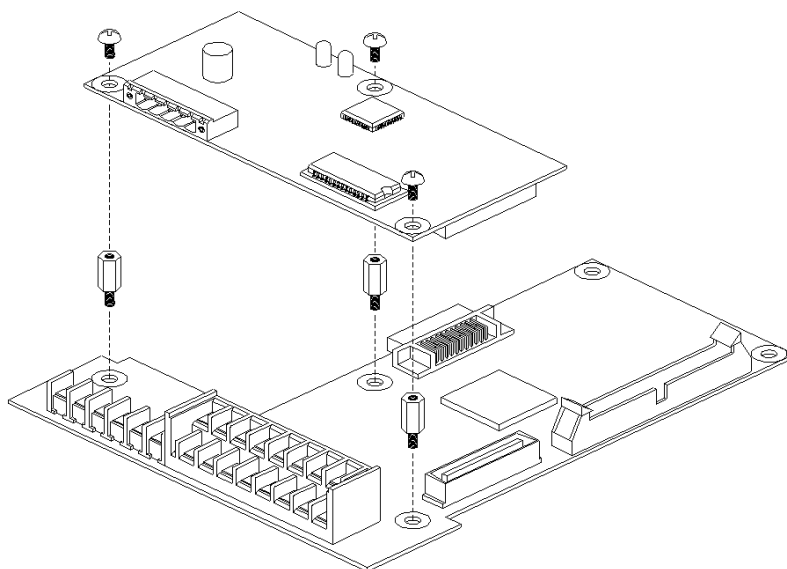

Figure 2 – Installing the DeviceNet Board to SV-iS5/iP5A series

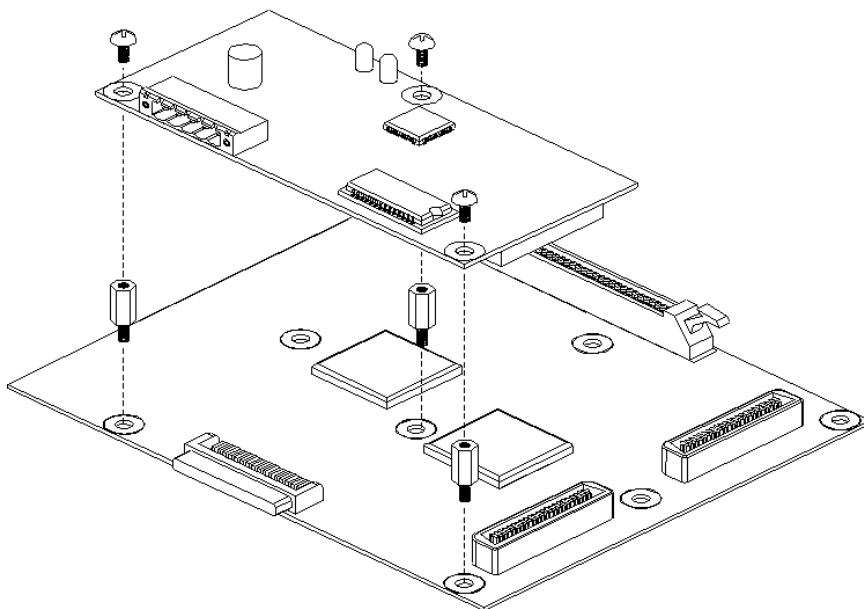

Figure 4 – Installing the DeviceNet Board to the SV-iV5 series

2.3 Setting the DeviceNet Parameter

2.3.1 Setting the MAC ID(Media Access Control Identifier)

1. MAC ID (Media Access Control Identifier) is a unique value to identify nodes in the DeviceNet Network. Therefore the each serial device on the network has a unique address.
2. Setting and changing MAC ID is available via keypad.
3. The factory default setting is DeviceNet address 63. If DPRAM communication between Inverter and the Option card becomes faulty, the value will default to Station Number 63.

Inverter	Display	Min Value	Max Value	Parameter Setting
SV-iS5	MAC ID	0	63	COM #10
SV-iP5A				EXT-80
SV-iV5				EXT-05

4. When MAC ID is changed during Run, Option board is automatically reset to find the device new MAC ID is allocated on the network. If a duplicate MAC ID is checked, NS (Network Status) LED turns Solid Red. In this case, it should be changed to different MAC ID. In the normal operation, LED color is flashing Green.

2.3.2 Setting the Baud Rate

1. Set Baud rate of DeviceNet

Inverter	Display	Min Value	Max Value	Parameter Setting
SV-iS5	Baud Rate	125(kbps)	500(kbps)	COM #10
SV-iP5A				EXT-81
SV-iV5				EXT-04

2. Baud Rate is classified with three according to communication distance

Baud Rate	Trunk Cable Length		Drop Length	
	Thick Cable	Thin Cable	Max Length	Total
125 kbps	500 m (1640 ft.)	100 m (328 ft.)	6 m (20 ft.)	156 m (512 ft.)
250 kbps	250 m (820 ft.)			78 m (256 ft.)
500 kbps	100 m (328 ft.)			39m (128ft.)

Note: The Baud Rate determines the maximum length of the DeviceNet cable. Refer to Table 1 to determine cable lengths and baud rates. The above is only met when DeviceNet-dedicated cables are used. For more information on the DeviceNet cables, makers and detail specifications, refer to the Open DeviceNet Vendor Association (ODVA) homepage at "<http://www.odva.org/>".

3. NS LED remains OFF when the setting of actual Network communication speed and Baud Rate does not match.
 4. Set the desirable Baud Rate via Keypad. Changing this parameter does not change the actual data rate until power is cycled. Reset the inverter or request Reset Service to the Inverter Reset Identity Object.
- ※ NS LED will turn to flashing Green when Network Baud Rate matches Baud Rate of the option card and a unique MAC ID is allocated.

2.3.3 Setting Lost command Decision Time

It is a set for emergency stop in case that Inverter and Master are not communicated. It works when communication is not activated even one time during the setting time. It means control of inverter is not activating by Remote. For safe operation, set this value please.

2.3.4 Setting Assembly Instance

Assembly Instance has four types of Sending/Receiving data through Poll I/O communication. Refer to **Assembly Object in 7 MESSAGE** for detailed information.

Inverter	Display	Min value	Max value	Function Code
SV-iS5	Out Instance	20	101	COM #12
SV-iP5A				COM-12
SV-iV5				EXT_06
SV-iS5	In Instance	70	111	COM #13
SV-iP5A				COM-13
SV-iV5				EXT_07

3 POLL I/O DATA

Poll I/O Connection is a Data transaction connection between Inverter and Scanner. The Input/output size of data is 4 bytes, Communication Rate is 0 (default).

Data transaction through Poll I/O is determined by the setting of Assembly Instance. Assembly Instance consists of Input and Output, based on Scanner side. Therefore, Input Data means data Scanner receives. For inverter side, it is the feedback value to Scanner. By contrast, Output Data is the data Scanner transmits to the Inverter as a new command.

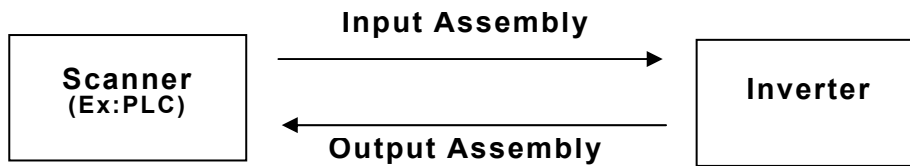

Figure 5 - Data Transaction via Poll I/O Communication

Instance Type	Scanner Side	Inverter Side
Input Assembly Data	Transmit data	Receive data
Output Assembly Data	Receive data	Transmit data

4 OPERATION

4.1 When Power Up or Reset is occurred

During a power up or reset, the option board:

1. Performs power up initialization. First Module Status LED flashes Green for 0.25sec to Red for 0.25sec and then turns to Solid Green when DPRAM is in normal operation.
2. Then, Network Status LED flashes Green for 0.25sec to Red for 0.25sec
3. After no duplicate MAC ID is detected, Network Status LED flashes Green, indicating the option board is successfully connected to the Network. However, communication with other nodes has not been initiated.

If the above steps is failed, follow the below steps. No action is required in the normal operating state.

1. When DPRAM is not working properly, Module Status LED turns Solid Red. In this case, Check the option board's connection with Inverter first and cycle the power.
 2. When NS remains OFF, not flashing Green,
 - A. Check the DeviceNet Power
 - B. Check the Baud Rate of Network and the Option board matches.
- When duplicate MAC ID error occurs, Network Status LED turns Solid Red. In this case, allocate the different MAC ID via Keypad.
 - When the option board is in communication with other nodes, NS (Network Status) LED turns Solid Green.

4.2 When EMC (Explicit Message Connection) is established by Scanner

- Network Status LED turns green. During this state, if EMC setting is deactivated, the LED will turn green after 10 seconds delay. Once EMC is connected, I/O Connection setting is available. At this time, the Network Status LED will not change.
- If I/O Connection is not established within given time, then Time Out will occur and Network Status LED turns flashing Red. (Depending on the time setting of EMC, the status can be changed to green again.)

5 TROUBLESHOOTING

The current status of Device and Network can be monitored through built-in LED (MS, NS).

[NS (Network Status) LED]

LED	Status	Cause	Diagnostics
OFF	Off-Line (No Power)	The option card is not receiving power from the Network.	Check DeviceNet power and cable connections and the power connection on the DeviceNet terminal block.
		Single node on the network	Check DeviceNet Master node operation for correct Communication.
		Incorrect Baud Rate is set.	Change the baud rate setting and reset the inverter.
Flashing Green	On-Line, Not Connected	Communication is set after duplicate node check is finished, but connection to other node is not completed.	Normal operating status before user makes connection.
Solid Green	On-Line Connected (Link OK)	More than one EMC connection is established.	Polled I/O connection is available.
Flashing Red	Connection Time-Out Critical Link Failure.	Polled I/O connection is Timed Out	Inverter Reset. Request Reset Service to the Inverter Reset Identity Object. Retry I/O connection.
Solid Red	Faults occurred	Duplicate MAC ID check failed	Change the setting of MAC ID.
		Bus Off State	Check for line connection
Green → Flashing Red	Self- diagnostic	Device is under self-diagnostic mode.	Wait for a moment.
Red → Flashing Green	Communication Fault	State of Communication Fault due to the failure to pass the Network Access. Identity communication Fault Request is accepted	No action required.

[MS (Module Status) LED]

LED	Status	Cause	Diagnostics
Off	No Power	5V Power is not applied to the option card.	Check the incoming power to inverter is provided. Check 5V power is ON.
Solid Green	Operational	Normal operation state	
Solid Red	Unrecoverable Fault	Data transaction through DPRAM is disrupted..	Check the connection between option card and Inverter.
Flashing Green & Red	Self Test	Device is in self-test mode.	

6 EDS FILE(ELECTRONIC DATA SHEET)

EDS files are specially formatted ASCII files that provide all of the information necessary for a configuration tool such as the DeviceNet Manager, to access and alter the parameters of a device. The EDS file contains information on the number of parameters in a device and how those parameters are grouped together. Information about each parameter is contained in this file such as parameter min, max, and default values, parameter data format and scaling and the parameter name and units. Install EDS files for iS5/iP5A/iV5 to control iS5/iP5A/iV5 parameters using DeviceNet Manager program. This file can be downloaded from : <http://www.lsis.biz> or contact your LS representative.

7 MESSAGE

- R: Read Only
- R/W: Read / Write enable

<Device Profile>

- AC/DC Drives: 0x 02

<Object Model>

Object Class Name	Class Code
Identity Object	0x01
Message Router	0x02
DeviceNet	0x03
Assembly	0x04
Connection	0x05
Motor Data	0x28
Control Supervisor	0x29
AC/DC Drive	0x2A
Inverter	0x64

< Identity Object>

Class Code	0x01
Instance	1 (All attributes are instance 1)

Attribute ID	Attribute Name	Access Method
1	Vendor ID	R
2	Device Type	R
3	Product Code	R
4	Revision	R
	Major Revision (High Byte)	
	Minor Revision (Low Byte)	

Attribute ID	Attribute Name	Access Method
5	Status ¹	R
6	Serial Number	R
7	Product Name	R

Service Name	Service Code	Implemented for:	
		Class	Instance
Get_Attribute_Single	0x0E	No	Yes
Reset	0x05	No	Yes
Set_Attribute_Single	0x10	No	Yes

< DeviceNet Object >

Class Code	0x03
Instance	1 (All attributes are instance 1)

Attribute ID	Attribute Name	Access Method
1	MAC ID ²	R/W
2	Baud Rate ³	R/W
3	BOI	Not support
4	Bus-Off Counter	Not support

¹ Status Attribute

Bit number	0 (Owned)	8 (Recoverable Minor Fault)	Other Bits
Meaning	Connected to the master	DPRAM Error	Not support

² Range of MAC ID: 0 to 63

³ Baud Rate

Value	0	1	2
Baud Rate	125 kbps	250 kbps	500 kbps

Attribute ID	Attribute Name	Access Method
5	Allocation Information: Allocation Choice Byte ⁴ Master's MAC ID	R
6	MAC ID Switch Changed	R
7	Baud Rate Changed	Not support
8	MAC ID Switch Value	Not support
9	Baud Rate Switch Value	Not support

Service Name	Service Code	Support for:	
		Class	Instance
Get_Attribute_Single	0x0E	Yes	Yes
Set_Attribute_Single	0x10	No	Yes
Allocate Master/Slave Connection Set	0x4B	No	Yes
Release Group2 Identifier Set	0x4C	No	Yes

< Assembly Object >

Class Code	0x04
Instance	1 (All attributes are instance 1)

Service Name	Service Code	Implemented for:	
		Class	Instance
Get_Attribute_Single	0x0E	No	Yes
Set_Attribute_Single	0x10	No	Yes

⁴ Allocation Choice Byte

7	6	5	4	3	2	1	0
Not Supported						Polled	Explicit Message

< Input Assembly Data Attribute Format >

Instance	Byte	Bit 7	Bit 6	Bit 5	Bit 4	Bit 3	Bit 2	Bit 1	Bit 0
70 (110)	0						Fault Reset		Run Fwd
	1								
	2	Speed Reference (Low Byte) – RPM unit (Speed Reference (Low Byte) – 0.01Hz unit)							
	3	Speed Reference (High Byte) – RPM unit (Speed Reference (High Byte) – 0.01Hz unit)							
71 (111)	0		NetRef	NetCtrl			Fault Reset	Run Rev	Run Fwd
	1								
	2	Speed Reference (Low Byte) – RPM unit (Speed Reference (Low Byte) – 0.01 Hz unit)							
	3	Speed Reference (High Byte) – RPM unit (Speed Reference (High Byte) – 0.01Hz unit)							

Name	Description	Related Attribute	
		Class	Attr. ID
Run Fwd	Forward Run Command	0x29	3
Run Rev	Reverse Run Command	0x29	4
Fault reset	Fault Reset Command	0x29	12
NetRef ⁵	Not used	0x2A	4
NetCtrl ⁵	Not used	0x29	5
Speed Reference	Speed Command	0x2A	8

⁵ Setting Reference Control and Run/Stop Control can Only be done via LCD Keypad. Therefore, NetRef, NetCtrl in Instance 21 and 101 is not available.

< Output Assembly Data Attribute Format >

Instance	Byte	Bit 7	Bit 6	Bit 5	Bit 4	Bit 3	Bit 2	Bit 1	Bit 0
20 (100)	0						Run- ning1		Faulted
	1								
	2	Speed Reference (Low Byte) – RPM unit (Speed Reference (Low Byte) – 0.01Hz unit)							
	3	Speed Reference (High Byte) – RPM unit (Speed Reference (High Byte) – 0.01Hz unit)							
21 (101)	0	At Ref.	Ref from Net	Ctrl from Net	Ready	Run- ning 2, (Rev)	Run- ning 1, (Fwd)	Warn- ing	Faulted
	1								
	2	Speed Reference (Low Byte) – RPM unit (Speed Reference (Low Byte) – 0.01Hz unit) ⁶							
	3	Speed Reference (High Byte) – RPM unit (Speed Reference (High Byte) – 0.01Hz unit)							

Name	Description	Related Attribute	
		Class	Attr. ID
Faulted	DPRAM or Inverter Error	0x29	10
Warning	Not Supported	0x29	11
Running1	Motor is running Forward	0x29	7
Running2	Motor is running Reverse	0x29	8
Ready	Motor is ready to run	0x29	9
Ctrl From Net	Run/Stop control	0x29	15
Ref From Net	Speed control	0x2A	29
At Reference	Reach at Reference Speed	0x2A	3
Drive State	Current Motor State	0x29	6
Speed Actual	Speed Command	0x2A	7

< Connection Object >

Class Code	0x05	
Instance	1	Predefined EMC
	2	Poll I/O
	6, 7, 8, 9, 10	Dynamic EMC

Attribute ID	Attribute Name	Access Method	
		I/O	EMC
		Established/ Timed Out	Established/ Deferred delete
1	State	R	R
2	Instance_type	R	R
3	TransportClass_trigger	R	R
4	Produced_connection_id	R/W	R
5	Consumed_connection_id	R/W	R
6	initial_comm_characteristics	R	R
7	Produced_connection_size	R	R
8	Consumed_connection_size	R	R
9	Expected_packet_rate	R/W	R/W
10 – 11	N/A		
12	Watchdog_timeout_action	R/W	R/W
13	Produced_connection_path_length	R	R
14	Produced_connection_path	R	R
15	Consumed_connection_path_length	R	R
16	Consumed_connection_path	R	R
17	Production_inhibit_time	R/W	R

Service Name	Service Code	Support for:	
		Class	Instance
Get_Attribute_Single	0x0E	No	Yes
Reset	0x05	No	Yes
Set_Attribute_Single	0x10	No	Yes

< Motor Data Object >

Class Code	0x28
Instance	1 (All attributes are instance 1)

Attribute ID	Attribute Name	Access Method
3	MotorType	R ⁶
6	RatedCurrent	R/W
7	RatedVoltage	R

Service Name	Service Code	Implemented for:	
		Class	Instance
Get_Attribute_Single	0x0E	No	Yes
Set_Attribute_Single	0x10	No	Yes

< Control Supervisor Object >

Class Code	0x29
Instance	1 (All attributes are instance 1)

Attribute ID	Attribute Name	Access Method
3	Run 1 (Forward command)	R/W
4	Run 2 (Reverse command)	R/W
5	NetCtrl ⁷	R
6	State	R
7	Running1 (Forward running)	R
8	Running2 (Reverse running)	R
9	Ready	R
10	Faulted	R
12	FaultRst	R/W
13	FaultCode	R
15	CtrlFromNet	R

⁶ MotorType Attribute Squirrel Cage Induction Motor: #7

⁷ NetCtrl Attribute: This Attribute setting determines the control location for the motor. This value only can be set through the keypad for the safety reason. Changing this via DeviceNet does not cause error and cannot affect the setting.

Service Name	Service Code	Implemented for:	
		Class	Instance
Get_Attribute_Single	0x0E	No	Yes
Set_Attribute_Single	0x10	No	Yes

< AC/DC Drive Object >

Class Code	0x2A
Instance	1 (All attributes are instance 1)

Attribute ID	Attribute Name	Access Method
3	AtReference	R
4	NetRef ⁸	R/W
6	DriveMode	R/W
7	SpeedActual	R
8	SpeedRef	R/W
9	CurrentActual	R
29	RefFromNet	R
100	Actual Hz	R
101	Reference Hz	R/W
102	Acc. Time	R/W
103	Dec. Time	R/W

Service Name	Service Code	Support for:	
		Class	Instance
Get_Attribute_Single	0x0E	No	Yes
Set_Attribute_Single	0x10	No	Yes

⁸ NetRef Attribute

This setting is only done via Keypad for safety reason. Changing this via DeviceNet does not cause error and cannot affect the setting.

< Inverter Object >

SV-iS5/iP5A Instance

Class Code	0x64		Attribute Number
Instance	1	DRV Group	SV-iS5/iP5A Parameter code # + 1
	2	FU1/FU2 Group	Same as iS5/iP5A Parameter code #
	3	I/O Group	Same as iS5/iP5A Parameter code #
	4	COM Group	Same as iS5/iP5A Parameter code #
	5	APP Group	Same as iS5/iP5A Parameter code #

SV-iV5 Instance

Class Code	0x64		Attribute Number
Instance	2	Display Group	SV-iV5 Parameter code # + 1
	3	DIO Group	Same as SV-iV5 Parameter code #
	4	Parameter Group	Same as SV-iV5 Parameter code #
	5	Function Group	Same as SV-iV5 Parameter code #
	6	Control Group	Same as SV-iV5 Parameter code #
	7	External Group	Same as SV-iV5 Parameter code #
	8	AIO Group	Same as SV-iV5 Parameter code #
	9	User Group	Same as SV-iV5 Parameter code #
	10	2 nd Group	Same as SV-iV5 Parameter code #
	11	Elevator Group	Same as SV-iV5 Parameter code #
	12	Sychro Group	Same as SV-iV5 Parameter code #
	13	WEB Group	Same as SV-iV5 Parameter code #

Note) Refer to inverter manual for reference of Attribute Number. It is the same as Parameter Code Number.

Service Name	Service Code	Implemented for:	
		Class	Instance
Get_Attribute_Single	0x0E	No	Yes
Set_Attribute_Single	0x10	No	Yes

8 PARAMETER CODE (HEX)

8.1 SV-iS5 Parameter Code

8.1.1 SV-iS5 Function Code

< DRV Group >

Address	Parameter No.	Parameter Name	Default	Max value	Min value	Unit
5100	DRV#00	Cmd. freq	0	MaxFreq	0	0.01Hz
5101	DRV#01	Acc. Time	100	6000	0	0.1sec
5102	DRV#02	Dec. Time	200	6000	0	0.1sec
5103	DRV#03	Drive mode	1	2	0	
5104	DRV#04	Freq. mode	0	4	0	
5105	DRV#05	Step freq - 1	1000	MaxFreq	StartFreq	0.01Hz
5106	DRV#06	Step freq - 2	2000	MaxFreq	StartFreq	0.01Hz
5107	DRV#07	Step freq - 3	3000	MaxFreq	StartFreq	0.01Hz
5108	DRV#08	Current	-	-	-	0.1A
5109	DRV#09	Speed	-	-	-	1rpm
510A	DRV#10	DC Link Voltage		-	-	V
5110	DRV #16	Hz/Rpm Disp	*	-	-	Hz/Rpm

< FU1 Group >

Address	Parameter No.	Parameter Name	Default	Max value	Min value	Unit
5203	FU1 #03	Run prohibit	0	2	0	
5205	FU1 #05	Acc. pattern	0	4	0	
5206	FU1 #06	Dec. pattern	0	4	0	
5207	FU1 #07	Stop mode	0	2	0	
5208	FU1 #08	DcBr freq.	500	6000	StartFreq	0.01Hz
5209	FU1 #09	DcBlk time	10	6000	0	0.01sec
520A	FU1 #10	DcBr value	50	200	0	%
520B	FU1 #11	DcBr time	10	600	0	0.1sec
520C	FU1 #12	DcSt value	50	200	0	%
520D	FU1 #13	DcSt time	0	600	0	0.1sec
520E	FU1 #14	PreExTime	10	600	0	0.1sec

Address	Parameter No.	Parameter Name	Default	Max value	Min value	Unit
520F	FU1 #15	Hold time	1000	10000	0	1msec
5210	FU1 #16	Flux Force	1000	5000	1000	0.1%
5214	FU1 #20	Max freq.	6000	40000	4000	0.01Hz
5215	FU1 #21	Base freq.	6000	MaxFreq	3000	0.01Hz
5216	FU1 #22	Start freq.	50	6000	1	0.01Hz
5217	FU1 #23	Freq limit	0	1	0	
5218	FU1 #24	F-limit Lo.	50	HighFreq	StartFreq	0.01Hz
5219	FU1 #25	F-limit Hi.	6000	MaxFreq	LowFreq	0.01Hz
521A	FU1 #26	Torque boost	0	1	0	
521B	FU1 #27	Fwd boost	20	150	0	0.1%
521C	FU1 #28	Rev boost	20	150	0	0.1%
521D	FU1 #29	V/F pattern	0	2	0	
521E	FU1 #30	User freq. 1	1500	MaxFreq	0	0.01Hz
521F	FU1 #31	User volt. 1	25	100	0	%
5220	FU1 #32	User freq. 2	3000	MaxFreq	0	0.01Hz
5221	FU1 #33	User volt. 2	50	100	0	%
5222	FU1 #34	User freq. 3	4500	MaxFreq	0	0.01Hz
5223	FU1 #35	User volt. 3	75	100	0	%
5224	FU1 #36	User freq. 4	6000	MaxFreq	0	0.01Hz
5225	FU1 #37	User volt. 4	100	100	0	%
5226	FU1 #38	Volt control	1000	1100	400	0.1%
5227	FU1 #39	Energy save	0	30	0	%
5232	FU1 #50	ETH select	0	1	0	
5233	FU1 #51	ETH 1min	180	200	ETH Cont	%
5234	FU1 #52	ETH Cont	100	150	50	%
5235	FU1 #53	Motor type	0	1	0	
5236	FU1 #54	OL level	150	150	30	%
5237	FU1 #55	OL time	100	300	0	0.1sec
5238	FU1 #56	OLT select	1	1	0	
5239	FU1 #57	OLT level	180	200	30	%
523A	FU1 #58	OLT time	600	600	0	0.1sec
523B	FU1 #59	Stall prev.	0	7	0	
523C	FU1 #60	Stall level	180	250	30	%

< FU2 Group >

Address	Parameter No.	Parameter Name	Default	Max value	Min value	Unit
5307	FU2 #07	Dwell freq	500	MaxFreq	StartFreq	0.01Hz
5308	FU1 #08	Dwell time	0	100	0	0.1sec
530A	FU2 #10	Jump freq	0	1	0	
530B	FU2 #11	Jump lo 1	1000	Jump Hi 1	StartFreq	0.01Hz
530C	FU2#12	Jump Hi 1	1500	MaxFreq	Jump Lo 1	0.01Hz
530D	FU2 #13	Jump lo 2	2000	Jump Hi 2	StartFreq	0.01Hz
530E	FU2 #14	Jump Hi 2	2500	MaxFreq	Jump Lo 2	0.01Hz
530F	FU2 #15	Jump lo 3	3000	Jump Hi 3	StartFreq	0.01Hz
5310	FU2 #16	Jump Hi 3	3500	MaxFreq	Jump Lo 3	0.01Hz
5311	FU2 #17	Start Curve	40	100	1	%
5312	FU2 #18	End Curve	40	100	1	%
5313	FU2 #19	Trip select	0	3	0	BIT
5314	FU2 #20	Power-on run	0	1	0	
5315	FU2 #21	RST restart	0	1	0	
5316	FU2 #22	Speed Search	0	15	0	BIT
5317	FU2 #23	SS Sup-Curr	100	200	80	
5318	FU2 #24	SS P-gain	100	9999	0	
5319	FU2 #25	SS I-gain	1000	9999	0	
531A	FU2 #26	Retry number	0	10	0	
531B	FU2 #27	Retry delay	10	600	0	0.1sec
531C	FU2 #28	SS blk time	10	600	0	0.1sec
531E	FU2#30	Motor select	0	9	0	
531F	FU2#31	Pole number	4	12	2	
5320	FU2 #32	Rated-Slip	Depends on Motor and Voltage	1000	0	0.01Hz
5321	FU2 #33	Rated-Curr		2000	10	0.1A
5322	FU2 #34	Noload-Curr		2000	5	0.1A
5323	FU2 #35	Motor Volt		460	180	V
5324	FU2 #36	Efficiency		100	70	%
5325	FU2 #37	Inertia rate	0	1	0	
5327	FU2 #39	Carrier freq	50	150	10	0.1kHz
5328	FU2 #40	Control mode	0	2	0	
5329	FU2 #41	Rs	Depends	1	0	

Address	Parameter No.	Parameter Name	Default	Max value	Min value	Unit
532A	FU2 #42	Lsigma	on motor and Auto-tunning	5000	0	0.001ohm
532B	FU2 #43	Ls		5000	0	0.001ohm
532C	FU2 #44	Tr		MaxInduc	0	0.001mH
532D	FU2 #45	SL P-gain	32767	32767	0	
532E	FU2 #46	SL I-gain	3276	32767	0	
532F	FU2 #47	proc PI mode	0	1	0	
5330	FU2 #48	PID F-gain	0	9999	0	0.1%
5331	FU2 #49	Aux Ref Mode	0	5	0	
5332	FU2 #50	PID Out Dir	1	1	0	
5333	FU2 #51	PID F/B	0	2	0	
5334	FU2 #52	PID P-gain	3000	9999	0	0.1%
5335	FU2 #53	PID I-time	10	320	0	0.1sec
5336	FU2 #54	PID D-time	0	9999	0	0.1msec
5337	FU2 #55	PID +limit	6000	MaxFreq	0	0.01Hz
5338	FU2 #56	PID -limit	6000	MaxFreq	0	0.01Hz
5339	FU2 #57	PID Out Inv	0	1	0	
533A	FU2 #58	PID OutScale	1000	9999	1	0.1%
533B	FU2 #59	PID P2-gian	1000	9999	0	0.1%
533C	FU2 #60	P-gain Scale	1000	1000	0	0.1%
5345	FU2 #69	Acc/Dec ch F	0	MaxFreq	0	0.01Hz
5346	FU2 #70	Acc/Dec freq	0	1	0	
5347	FU2 #71	Time scale	1	2	0	
5348	FU2 #72	PowerOn disp	0	12	0	
5349	FU2 #73	User disp	0	2	0	
534A	FU2 #74	RPM factor	100	1000	1	%
534B	FU2 #75	DB mode	1	2	0	
534C	FU2 #76	DB %ED	10	30	0	%
5351	FU2 #81	2nd Acc time	50	6000	0	0.1sec
5352	FU2 #82	2nd Dec time	100	6000	0	0.1sec
5353	FU2 #83	2nd BaseFreq	6000	maxFreq	3000	0.01Hz
5354	FU2 #84	2nd V/F	0	2	0	
5355	FU2 #85	2nd F-boost	20	150	0	0.1%
5356	FU2 #86	2nd R-boost	20	150	0	0.1%

Address	Parameter No.	Parameter Name	Default	Max value	Min value	Unit
5357	FU2 #87	2nd Stall	150	150	30	%
5358	FU2 #88	2nd ETH 1min	180	200	2nd ETH Cont	%
5359	FU2 #89	2nd ETH Cont.	120	2nd ETH 1min	50	%
535A	FU2 #90	2nd R-Curr	36	2000	10	0.1A
535D	FU2 #93	Para. Init	0	8	0	

< I/O Group >

Address	Parameter No.	Parameter Name	Default	Max value	Min value	Unit
5401	I/O #01	V1 filter	10	9999	0	ms
5402	I/O #02	V1 volt x1	0	V1 vort x2	0	0.01V
5403	I/O #03	V1 freq y1 / V1 % y1	0 0	Max freq 1500	0 0	0.01Hz 0.1%
5404	I/O #04	V1 volt x2	1000	1000	V1 volt x1	0.01V
5405	I/O #05	V1 freq y2 / V1 % y2	6000 1500	Max freq 1500	0 0	0.01Hz 0.1%
5406	I/O #06	I filter	10	9999	0	ms
5407	I/O #07	I curr x1	400	I curr x2	0	0.01mA
5408	I/O #08	I freq y1	0	Max freq	0	0.01Hz
5409	I/O #09	I curr x2	2000	2000	I curr x1	0.01mA
540A	I/O #10	I freq y2	6000	Max freq	0	0.01Hz
540B	I/O #11	Wire broken	0	2	0	
540C	I/O #12	P1 define	0	42	0	
540D	I/O #13	P2 define	1	42	0	
540E	I/O #14	P3 define	2	42	0	
5411	I/O #17	Ti Filt Num	15	50	2	
5414	I/O #20	Jog freq	1000	MaxFreq	StartFreq	0.01Hz
5415	I/O #21	Step freq - 4	4000	MaxFreq	StartFreq	0.01Hz
5416	I/O #22	Step freq - 5	5000	MaxFreq	StartFreq	0.01Hz
5417	I/O #23	Step freq - 6	4000	MaxFreq	StartFreq	0.01Hz
5418	I/O #24	Step freq - 7	3000	MaxFreq	StartFreq	0.01Hz
5419	I/O #25	Acc time- 1	200	6000	0	0.1sec

Address	Parameter No.	Parameter Name	Default	Max value	Min value	Unit
541A	I/O #26	Dec time – 1	200	6000	0	0.1sec
541B	I/O #27	Acc time – 2	300	6000	0	0.1sec
541C	I/O #28	Dec time – 2	300	6000	0	0.1sec
541D	I/O #29	Acc time – 3	400	6000	0	0.1sec
541E	I/O #30	Dec time - 3	400	6000	0	0.1sec
541F	I/O #31	Acc time – 4	500	6000	0	0.1sec
5420	I/O #32	Dec time – 4	500	6000	0	0.1sec
5421	I/O #33	Acc time – 5	400	6000	0	0.1sec
5422	I/O #34	Dec time – 5	400	6000	0	0.1sec
5423	I/O #35	Acc time – 6	300	6000	0	0.1sec
5424	I/O #36	Dec time – 6	300	6000	0	0.1sec
5425	I/O #37	Acc time – 7	200	6000	0	0.1sec
5426	I/O #38	Dec time – 7	200	6000	0	0.1sec
5428	I/O #40	FM mode	0	3	0	
5429	I/O #41	FM adjust	100	200	10	%
542A	I/O #42	FDT freq	3000	MaxFreq	0	0.01Hz
542B	I/O #43	FDT band	1000	MaxFreq	0	0.01Hz
542C	I/O #44	Aux mode	12	23	0	
542D	I/O #45	Relay mode	2	7	0	BIT3
542E	I/O #46	Inv No.	1	31	1	
542F	I/O #47	Baud rate	3	4	0	
5430	I/O #48	Lost command	0	2	0	
5431	I/O #49	Time out	10	1200	1	0.1sec

Note) If you need to know specific parameter addresses for Auto Sequence Operation, contact LS representatives.

< EXT Group >

Address	Parameter No.	Parameter Name	Default	Max value	Min value	Unit
5501	EXT #01	Sub B/D	0	8	0	
5502	EXT #02	P4 define	3	42	0	
5503	EXT #03	P5 define	4	42	0	
5504	EXT #04	P6 define	5	42	0	
5505	EXT #05	V2 mode	0	2	0	
5506	EXT #06	V2 filter	10	9999	0	msec
5507	EXT #07	V2 volt x1	0	V2 volt x2	0	0.01V
5508	EXT #08	V2 freq y1	0	Max freq	0	0.01Hz
5509	EXT #09	V2 volt x2	1000	1000	V2 volt x1	0.01V
550A	EXT #10	V2 freq y2	6000	Max freq	0	0.01Hz
550C	EXT #12	F mode	0	2	0	
550F	EXT #15	F pulse set	0	2	0	
5510	EXT #16	F pulse num	1024	4096	360	
5511	EXT #17	F filter	10	9999	0	msec
5512	EXT #18	F pulse x1	0	F pulse x2	0	0.1kHz
5513	EXT #19	F freq y1	0	Max freq	0	0.01Hz
5514	EXT #20	F pulse x2	100	1000	F pulse x1	0.1kHz
5515	EXT #21	F freq y2	6000	Max freq	0	0.01Hz
5516	EXT #22	PG P-gain	3000	9999	0	
5517	EXT #23	PG I-gain	50	9999	0	
5518	EXT #24	PG Slip Freq	100	200	0	%
5519	EXT #25	ASR P-Gain	1000	5000	100	0.1%
551A	EXT #26	ASR I-Gain	200	9999	10	msec
551B	EXT #27	Trq + Limit	180	200	0	%
551C	EXT #28	Trq - Limit	180	200	0	%
551E	EXT #30	Q1 define	0	23	0	
551F	EXT #31	Q2 define	1	23	0	
5520	EXT #32	Q3 define	2	23	0	
5522	EXT #34	LM mode	1	3	0	
5523	EXT #35	LM adjust	100	200	10	%
5528	EXT #40	AM1 mode	0	3	0	

Address	Parameter No.	Parameter Name	Default	Max value	Min value	Unit
5529	EXT #41	AM1 adjust	100	200	10	%
552A	EXT #42	AM2 mode	3	3	0	
552B	EXT #43	AM2 adjust	100	200	10	%
5532	EXT #50	Speed Limit	100	200	0	%
5533	EXT #51	Speed Bias	100	200	0	%
5534	EXT #52	Speed Gain	1	10	1	
5535	EXT #53	Speed Dir	1	1	0	
5536	EXT #54	ZSD Level	200	12000	0	0.01Hz
5537	EXT #55	ZSD Band	100	500	0	0.01Hz
5538	EXT #56	TD Level	1000	1500	0	0.1%
5539	EXT #57	TD Band	50	100	0	0.1%

< COM Group >

Address	Parameter No.	Parameter Name	Default	Max value	Min value	Unit
5601	COM #01	Opt B/D	0	7	0	
5602	COM #02	Opt mode	0	3	0	
5603	COM #03	Opt version	x.x			
560A	COM #10	Baud Rate	125	500	125	kbps
560B	COM #11	MAC ID	63	63	0	
561C	COM #12	Out Instance	20	101	20	
561D	COM #13	In Instance	70	111	70	

< APP Group >

Address	Parameter No.	Parameter Name	Default	Max value	Min value	Unit
5701	APP #01	APP mode	0	3	0	
5702	APP #02	Trv. Amp[%]	0	200	0	0.1%
5703	APP #03	Trv. Scr	0	500	0	0.1%
5704	APP #04	Trv Acc Time	20	6000	1	0.1sec
5705	APP #05	Trv Dec Time	30	6000	1	0.1sec
5706	APP #06	Trv Off Hi	0	200	0	0.1%
5707	APP #07	Trv Off Lo	0	200	0	0.1%
5701	APP #01	APP mode	0	3	0	

Address	Parameter No.	Parameter Name	Default	Max value	Min value	Unit
5702	APP #02	Trv. Amp[%]	0	200	0	0.1%
5703	APP #03	Trv. Scr	0	500	0	0.1%
5704	APP #04	Trv Acc Time	20	6000	1	0.1sec
5705	APP #05	Trv Dec Time	30	6000	1	0.1sec
5706	APP #06	Trv Off Hi	0	200	0	0.1%
5707	APP #07	Trv Off Lo	0	200	0	0.1%
5708	APP #08	Aux Mot Run	0	4	0	
5709	APP #09	Starting Aux	1	4	1	
570A	APP #10	Auto Op Time	0	5940	0	
570B	APP #11	Start freq1	4999	Max freq	0	0.01Hz
570C	APP #12	Start freq2	4999	Max freq	0	0.01Hz
570D	APP #13	Start freq3	4999	Max freq	0	0.01Hz
570E	APP #14	Start freq4	4999	Max freq	0	0.01Hz
570F	APP #15	Stop freq1	1500	Max freq	0	0.01Hz
5710	APP #16	Stop freq2	1500	Max freq	0	0.01Hz
5711	APP #17	Stop freq3	1500	Max freq	0	0.01Hz
5712	APP #18	Stop freq4	1500	Max freq	0	0.01Hz
5713	APP #19	Aux start DT	600	9999	0	0.1sec
5714	APP #20	Aux stop DT	600	9999	0	0.1sec
5715	APP #21	Nbr Aux'	4	4	0	
5716	APP #22	Regul Bypass	0	1	0	
5717	APP #23	Sleep Delay	600	9999	0	0.1sec
5718	APP #24	Sleep Freq	19	Max freq	0	0.01Hz
5719	APP #25	WakeUp level	35	100	0	1%
571A	APP #26	AutoCh_Mode	1	2	0	
571B	APP #27	AutoEx intv	4320	5940	0	0.1sec
571C	APP #28	AutoEx level	20	100	0	1%
571D	APP #29	Inter-lock	0	1	0	
571E	APP #30	ActualF/P	*	100	0	%
571F	APP #31	Actual B/kPa	*	65472	0	Bar/Pa
5720	APP #32	Scale Disp	1000	50000	0	
5721	APP #33	Draw mode	0	3	0	
5722	APP #34	DrawPerc	100	150	0	1%

8.1.2 SV-iS5 Communication Option Setting

<COM Group>

COM-01 [Opt B/D]

Indicates Option boards installed. This value is automatically set when the boards are installed..

COM-02 [Opt Mode]

Determines whether Run/Stop/Reference Frequency is set via Communication.

Value	Display	Description
0	None	Disabled
1	Command	Run/Stop setting via Communication
2	Freq	Frequency setting via Communication
3	Cmd + Freq	Run/Stop/Reference Frequency via Communication

COM-03 [Opt Version]

Displays version of Option Board.

<I/O Group>

Address	No	Description	Factory Default	Setting Range
5430	I/O #48	How to operation when lost communication command	0 (None)	0 (None Keep operation) 1 (FreeRun Stop) 2 (Stop Decel stop)
5431	I/O #49	Decision time of Communication command lost	1.0sec	1.0~120.0sec

- When COM #02 1(Command) ~ 3 (Cmd + Freq), it operates by the set value of I/O #48 while lost communication command during the set time of I/O #49.

8.2. SV-iP5A Parameter Code

8.2.1 SV-iP5A Function Code

※ Please refer to SV-iP5A User manual for Communication address of Function code.

8.2.2 SV-iP5A Communication Option Setting

<COM 그룹>

COM-01 [Opt B/D]

Indicates Option boards installed. This value is automatically set when the boards are installed

COM-02 [Opt mode]

Determines whether Run/Stop/Reference Frequency is set via Communication.

Value	Display	Description
0	None	Disabled
1	Command	Run setting via Communication
2	Freq	Frequency setting via Communication
3	Cmd + Freq	Run/Reference Frequency via Communication

COM-03 [Opt Version]

Displays version of Option Board.

<I/O Group>

Address	No	Description	Factory Default	Setting Range
945C	I/O-92	How to operation when lost communication command	0 (None)	0 (None Keep operation) 1 (FreeRun Stop) 2 (Stop Decel stop)
945D	I/O-93	Decision time of Communication command lost	1.0sec	1.0~120.0sec

When COM #02 1(Command) ~ 3 (Cmd + Freq), it operates by the set value of I/O #92 while lost communication command during the set time of I/O #93.

8.3. SV-iV5 Parameter Code

8.3.1 SV-iV5 Function Code

※ Please refer to SV-iV5 User manual for Communication address of Function code.

8.3.2 SV-iV5 Communication Option Setting

<FUN Group>

Address	No	Description	Set value
7401	FUN_01	Run/Stop Select	Set into 3(OPTION)
7402	FUN_02	Speed Command select	Set into 3(OPTION)

Determines whether Run/Stop/Reference Frequency is set via Communication in FUN_01,02

<DIO Group>

Address	No	Description	Factory Default	Setting Range
7261	DIO_97	How to operation when lost communication command	0 (None)	0 (None Keep operation) 1 (FreeRun Stop) 2 (Stop Decel stop)
7262	DIO_98	Decision time of Communication command lost	1.0sec	1.0~30.0sec

When FUN_01:3(Optional) Or FUN_02:3(Optional), it operates by the set value of I/O #97 while lost communication command during the set time of I/O #98.

<EXT Group>

EXT_01 [Opt B/D]

Indicates Option boards installed. This value is automatically set when the boards are installed

EXT_02 [Opt Version]

Displays version of Option Board.